

SERVICE TOOLS

TUBE CUTTERS

IMPERIAL®

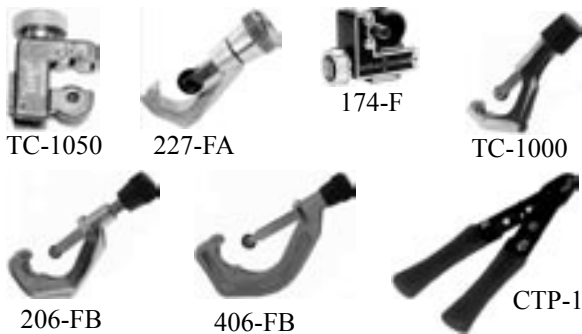

CODE	MODEL	RANGE	LIST £
060001	TC-1050	'Imp'® 1/8" to 5/8"	16.71
060003	227-FA	'Junior'® 1/8" to 3/4"	19.99
060004	TC-1000	'Hi-Duty'® 1/8" to 1-1/8"	28.33
060031	TC-1020	As above with constrictor	41.79
060005	312-FC	'Hi-Duty'® 1/4" to 1-5/8"	50.92
060007	174-F	'Big Imp'® 3/8" to 1-1/8"	33.67
060002	206-FB	'Adjust-O-Matic'® 3/8" to 2-5/8"	78.58
060006	406-FA	'Hi-Duty'® 2" to 4-1/8"	168.34
060032	CTP-1	Capillary tube cutter	12.47

YELLOW JACKET®

CODE MODEL RANGE

061440	60121	1/8" to 7/8"
061441	60101	1/8" to 1-1/8"
061442	60102	1/4" to 1-5/8"
061443	60139	3/8" to 2-5/8"
061444	60146	2" to 5-1/8"

LIST £

11.95
23.40
31.19
61.44
111.64



061439 60122 Flare cut-off tool

28.64

FLARING TOOLS

IMPERIAL®



CODE	MODEL	RANGE	LIST £
060025	375-FS	2 bars & 1 yoke 1/8"; 3/16"; 1/4"; 5/16"; 3/8"; 7/16"; 1/2"; 5/8"; 3/4"	99.81
060021	195-FC	3/16"; 1/4"; 5/16"; 3/8"; 7/16"; 1/2"; 5/8"	55.20
060024	300-FB	'Hi-Duty'® 3/16"; 1/4"; 5/16"; 3/8"; 1/2"; 5/8"	70.74
060026	500-FC	'Rol-Air'® 3/16"; 1/4"; 5/16"; 3/8"; 1/2"; 5/8"	80.83
060027	500-FCM	'Rol-Air'® 6; 8; 10; 12; 15; 16mm	135.12
060028	525-F	'Grabber Rol-Air'® 3/16" to 5/8"	73.89
060022	203-FA	5/8"; 3/4"; 7/8"; 1-1/8"	114.95
060020	103-FS	3/4"; 7/8"; 1"	114.05

YELLOW JACKET®

CODE MODEL RANGE

061445	60240	1/8"; 3/16"; 1/4"; 5/16"; 3/8"; 7/16"; 1/2"; 5/8"; 3/4"
061446	60201	'Premium' 3/16"; 1/4"; 5/16"; 3/8"; 1/2"; 5/8"
061448	60280	'Deluxe' 1/8" to 3/4"
061449	60295	'Eccentric Cone' 3/16" to 3/4"

LIST £

66.55
66.15
78.51
85.12

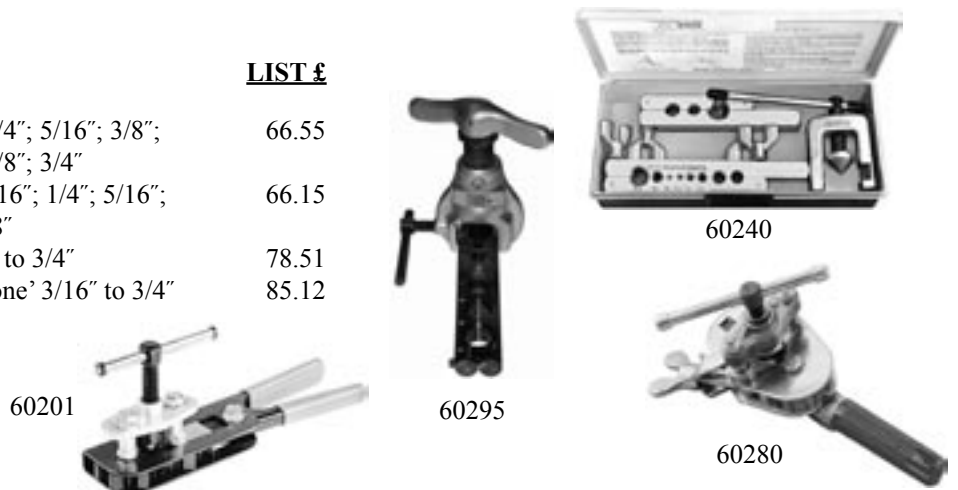

SERVICE TOOLS

TOOL KITS



121-F



555-FS



1226-FA



123-FA

IMPERIAL®

CODE	MODEL	DESCRIPTION	LIST £
060023	275-FS	Flaring and swaging tool suitable for 1/8"; 3/16"; 1/4"; 5/16"; 3/8"; 7/16"; 1/2"; 5/8"; 3/4" OD tube.	154.54
060029	555-FS	Production flaring and swaging tool suitable for 3/16"; 1/4"; 5/16"; 3/8"; 1/2"; 5/8" OD tube.	806.00
060053	120-F	Includes TC-1000 tube cutter and 375-FS flaring tool.	119.79
060054	121-F	Includes TC-1000 tube cutter, 375-FS flaring tool, 3 x 102-F bending springs for 1/4", 3/8" and 1/2" OD tube and 123-C ratchet wrench.	157.81
060055	124-FA	Includes TC-1000 tube cutter and 500-FC flaring tool.	114.76
060056	1226-FA	Flaring and cutting kit includes TC-1000 tube cutter and 195-FC flaring tool.	79.80
060057	123-FA	Includes TC-1000 tube cutter and 300-FB flaring tool.	119.24



120-F



275-FS

YELLOW JACKET®

061450	60440	Flaring and swaging tool suitable for 3/16"; 1/4"; 5/16"; 3/8"; 7/16"; 1/2"; 5/8"; 3/4"	108.49
--------	-------	---	--------



60440

TUBE TOOL SPARES

IMPERIAL®

CODE	MODEL	DESCRIPTION	LIST £
060008	32633	Cutter wheel for TC-1050/227-FA	5.79
060009	74761	Cutter wheel for 206-FB	13.45
060010	75015	Cutter wheel for 174-F/TC-1000/312-FC /TC-1020	6.95
060011	7931801	Reamer blade for TC-1000	9.78
060012	76637	Constrictor wheel for TC-1020	11.80
060013	75531	Bar assembly for 195-FC	34.92
060014	75534	Yoke assembly for 195-FC	29.24
060015	38905	Bar assembly for 103-FS	97.48
060016	38903	Yoke assembly for 103-FS/203-FA	85.06
060017	70603	Bar assembly for 203-FA	97.48
060850	75046	Heavy duty cutter wheel for 174-F/ TC-1000/312-FC/TC-1020	8.73
060851	74833	Cutter wheel for 406-FA	20.40
060852	38766	Bar assembly for 275-FS 1/8"; 3/16"; 1/4"; 5/16"; 3/8"; 7/16"	59.35
060853	38767	Bar assembly for 275-FS 1/2"; 5/8"; 3/4"	59.35
060854	7885801	Yoke assembly for 275-FS	43.40
060855	278-FS	Adapter for 275-FS 3/16"; 1/4"; 3/8"	23.17
060856	278-FS	Adapter for 275-FS 1/2"	23.17
060857	278-FS	Adapter for 275-FS 5/8"	23.17
060858	278-FS	Adapter for 275-FS 3/4"	35.50
060859	38600	Cone for 275-FS	15.69

YELLOW JACKET®

CODE	MODEL	DESCRIPTION	LIST £
061460	60120	Cutter wheel for 60121	3.82
061461	60110	Cutter wheel for 60122	4.60
061462	60100	Cutter wheel for 60101 & 60102	4.94
061464	60124	Cutter wheel for 60139	7.19
061465	60147	Cutter wheel for 60146	7.19

SERVICE TOOLS

HYDRAULIC FLARING AND SWAGING KIT

This kit features a hand-held hydraulic press that accurately flares and swages copper tubing. Once the die and adapter are secured in the fixture, a few pumps of the handle and you're done.

The kit includes dies and adapters for flaring and swaging copper tubing sizes: 1/4"; 5/16"; 3/8"; 1/2"; 5/8"; 3/4"; 7/8" and custom carrying case.

<u>CODE</u>	<u>MODEL</u>	<u>DESCRIPTION</u>	<u>LIST £</u>
061625	71700	Hydraulic flaring and swaging kit	235.61
061626	71700-A	Flaring and swaging pump	192.29
061627	71700-B	Yoke assembly	22.90
061628	71700-01	45° flaring cone	13.73
061629	71700-PB	Plastic moulded box	10.44
061630	71700-04	1/4" swaging adapter	13.00
061631	71700-05	5/16" swaging adapter	13.00
061632	71700-06	3/8" swaging adapter	13.00
061633	71700-08	1/2" swaging adapter	13.00
061634	71700-10	5/8" swaging adapter	13.00
061635	71700-12	3/4" swaging adapter	15.57
061636	71700-14	7/8" swaging adapter	15.57
061640	71700-104	1/4" die set	17.76
061641	71700-105	5/16" die set	17.76
061642	71700-106	3/8" die set	17.76
061643	71700-108	1/2" die set	17.76
061644	71700-110	5/8" die set	17.76
061645	71700-112	3/4" die set	19.23
061646	71700-114	7/8" die set	19.23



The hydraulic pump pushes in the forming adapter to fabricate the flare or swage.

The copper tube is secured in the holding fixture by the forming dies.

SWAGES



<u>CODE</u>	<u>MODEL</u>	<u>DESCRIPTION</u>	<u>LIST £</u>
060035	93-S-03	3/16" swage	5.79
060036	93-S-04	1/4" swage	5.11
060037	93-S-05	5/16" swage	7.23
060038	93-S-06	3/8" swage	5.63
060039	93-S-08	1/2" swage	7.24
060040	93-S-10	5/8" swage	8.99
060041	93-S-12	3/4" swage	14.12
060042	93-S-14	7/8" swage	17.71
060043	193-S	Case with 4 swaging punches: 1/4"; 3/8"; 1/2"; 5/8"	17.03
060045	94-S	Combination swaging punch: 1/2"; 5/8"; 7/8"	20.91
060047	60460	Combination swaging punch: 3/16"; 1/4"; 5/16"; 3/8"; 1/2"; 5/8"	11.18
060048	195-SA	Flaring bar and 4 swaging punches: 1/4"; 3/8"; 1/2"; 5/8"	75.84

PINCH-OFF TOOLS



<u>CODE</u>	<u>MODEL</u>	<u>RANGE</u>	<u>LIST £</u>
060050	105-FF	1/4"; 3/8"; 1/2"	35.19
060051	12396	up to 3/8"	26.12
060052		Lockgrips	19.76

PIERCING PLIERS



060100	SF4311	Piercing pliers	39.98
060101	SF4314	Replacement tip for above	4.48

REAMERS



060030	208-F	3/16" to 1-1/2" copper, aluminium and brass tube.	22.43
061437	60163	Deburring tool	23.47

SERVICE TOOLS

TUBE EXPANDERS

ROTHENBERGER



<u>CODE</u>	<u>MODEL</u>	<u>LIST £</u>
060125	KSO Tube Expander Tool only	210.07
060124	5/16" expander head	96.42
060116	3/8" expander head	91.79
060117	1/2" expander head	91.79
060118	5/8" expander head	91.79
060119	3/4" expander head	91.79
060120	7/8" expander head	91.79
060121	1-1/8" expander head	121.64
060122	1-3/8" expander head	121.64
060123	1-5/8" expander head	127.39
060126	Steel carrying case	53.52

EUROVAC



<u>CODE</u>	<u>MODEL</u>	<u>LIST £</u>
060147	TE-6 Tube Expander Kit in case with 3/8"; 1/2"; 5/8"; 3/4"; 7/8"; 1-1/8" heads	465.13
060157	TE-6-01 Tube Expander tool only	146.90
060148	H-3/8" expander head	77.92
060149	H-1/2" expander head	77.92
060150	H-5/8" expander head	77.92
060151	H-3/4" expander head	77.92
060152	H-7/8" expander head	77.92
060153	H-1-1/8" expander head	132.45
060154	H-1-3/8" expander head	136.20
060155	H-1-5/8" expander head	143.36

HYDRA-SWAGE

<u>CODE</u>	<u>MODEL</u>	<u>DESCRIPTION</u>	<u>LIST £</u>
061600	71600	7 Head Kit with 3/8", 1/2", 5/8", 3/4", 7/8", 1" and 1-1/8" expander heads, Hydra-Swage 71601 (6000psi), small adapter and 71685 inner reamer	476.94
061601	71650	10 Head Kit with 3/8", 1/2", 5/8", 3/4", 7/8", 1", 1-1/8", 1-3/8", 1-5/8" and 2-1/8" expander heads, Hydra-Swage 71601 (6000psi), small adapter and 71685 inner reamer	591.38
061603	71601	Hydra-Swage expander (6000 psi)	238.47
061604	71601-D	Adapter for 71601	12.64
061605	71685	Inner reamer	15.50
061606	71600-03	3/8" expander head	32.43
061607	71600-04	1/2" expander head	32.43
061608	71600-05	5/8" expander head	32.43
061609	71600-06	3/4" expander head	32.43
061610	71600-07	7/8" expander head	32.43
061611	71600-08	1" expander head	32.43
061612	71600-09	1-1/8" expander head	38.16
061613	71600-11	1-3/8" expander head	38.16
061614	71600-13	1-5/8" expander head	38.16
061615	71600-17	2-1/8" expander head	47.69
061616	71600-PB	Custom moulded case for 71600 and 71650	14.31



71650



71600

Fabricates and expands copper, aluminium and soft steel tubing using hydraulic power.

BENDING SPRINGS



<u>CODE</u>	<u>MODEL</u>	<u>SIZE</u>	<u>LIST £</u>
060058	102-F-04	1/4"	2.82
060059	102-F-05	5/16"	3.56
060060	102-F-06	3/8"	3.84
060061	102-F-08	1/2"	4.64
060062	102-F-10	5/8"	5.29
060063	102-F-12	3/4"	5.79

BABY 'S' BENDER



060065	'S' bender set comprising of handle, lever, formers and slippers to suit 3/8", 1/2" and 5/8" OD tube	138.48
060066	3/8" former	23.88
060067	1/2" former	27.01
060068	5/8" former	30.96
060069	3/8" slipper	8.12
060070	1/2" slipper	8.53
060071	5/8" slipper	8.86
060072	Forked handle	35.18
060073	Flat lever	42.34

SERVICE TOOLS

LEVER TYPE BENDERS

<u>CODE</u>	<u>MODEL</u>	<u>TUBE OD</u>	<u>RADIUS TO TUBE CENTRE</u>	<u>LIST £</u>
060074	364-FH-03	3/16"	7/16"	79.53
060075	364-FHB-04	1/4"	9/16"	67.37
060076	364-FHB-05	5/16"	11/16"	74.48
060077	364-FHB-06	3/8"	15/16"	77.96
060078	364-FHB-08	1/2"	1-1/2"	102.01
060079	364-FHA-10	5/8"	2-1/4"	139.77
060080	364-FHA-12	3/4"	3"	157.68
060081	364-FHA-14	7/8"	3"	326.39
060082	364-FHBM-06	6mm	14.2mm	74.60
060083	364-FHBM-08	8mm	17.5mm	78.20
060084	364-FHBM-10	10mm	24.0mm	97.69
060085	364-FHBM-12	12mm	38.1mm	163.68



WIDE RANGE TUBE BENDER

FURNISHED IN STEEL BOX WITH SPACE FOR OTHER TOOLS

<u>CODE</u>	<u>MODEL</u>	<u>TUBE OD</u>	<u>LIST £</u>
060086	260-FHA	1/4"; 5/16"; 3/8"; 1/2"; 5/8"; 3/4"; 7/8"	1093.56
060087	350-FHA	1/4"; 5/16"; 3/8"; 1/2"; 5/8"; 3/4"	832.09
060088	360-FHA	3/8"; 1/2"; 5/8"; 3/4"	596.90



TRIPLE HEADED BENDER

Innovative multi tube size design which does the work of three conventional lever type benders.

<u>CODE</u>	<u>MODEL</u>	<u>DESCRIPTION</u>	<u>LIST £</u>
060720	367-FH	"Imp" triple header tube bender for 1/8"; 3/16"; 1/4" OD tube	40.84
060721	368-FH	"Imp" triple header tube bender for 1/4"; 5/16"; 3/8" OD tube	49.16



MULTIBENDER

<u>CODE</u>	<u>MODEL</u>	<u>DESCRIPTION</u>	<u>LIST £</u>
060718	90614	Multibender	94.93

The industrial standard portable tube bender for copper and light grade stainless steel tube. Easy to use, lightweight, portable and robust with options for the most common refrigeration tube sizes. Each bender is complete with formers and guides for 1/2"; 5/8"; 3/4"; 7/8" OD tube.



RATCHET HEAD BENDER

<u>CODE</u>	<u>MODEL</u>	<u>DESCRIPTION</u>	<u>LIST £</u>
060715	60331	Ratchet hand bender 3/8" to 7/8"	239.12

Easy one-hand bending of soft copper, aluminium and light wall hydraulic tubing from 3/8" to 7/8".

- Bending shoes change quickly
- Trouble free ratchet mechanism
- Bend 3/4" tube to 90° in less than 10 seconds

Complete bender kit includes all required components to bend 3/8"; 1/2"; 5/8"; 3/4"; 7/8".



SERVICE TOOLS

WRENCHES

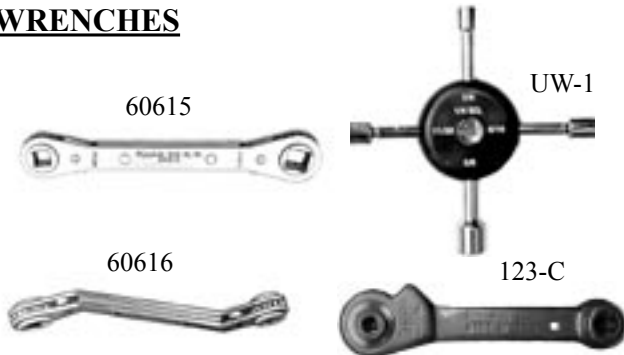

CODE	MODEL	DESCRIPTION	LIST £
060271		6" adjustable wrench	6.46
060272		8" adjustable wrench	8.63
060273		10" adjustable wrench	11.47
060274		12" adjustable wrench	20.74
060290	UW-1	Universal wrench 1/4"; 5/16"; 11/32"; 3/8"	17.33
060297	60615	Reversible wrench 3/8"; 1/2"	14.78
060298	60616	Offset wrench 3/16"; 1/4"; 5/16"; 3/8"	9.16
060301	D-72	1/4" square drive ratchet wrench	32.19
060302	123-C	1/4" square drive ratchet wrench with 3/16" & 1/4" square drive and 1/2" hex handle	24.64
060303	124-C	Ratchet wrench with 9/16" & 1/2" hex and 1/4" & 3/16" square	21.05
060304	125-C	1/4" square drive ratchet wrench with 3/16"; 1/4"; 5/16" square and 9/16" hex at other end	63.09
060305	127-C	Reversible ratchet wrench with 1/4" & 3/8" and 3/16" & 5/16" square drive ratchets	14.96

HEXAGONAL KEY SETS

CODE	DESCRIPTION	LIST £
060284	Imperial key set 1/16"; 5/64"; 3/32"; 1/8"; 5/32"; 3/16"; 7/32"; 1/4"; 5/16"; 3/8"	9.47
060285	Metric key set 1.5; 2; 2.5; 3; 4; 5; 5.5; 6; 8; 10 mm	9.47



MAGNETIC WRENCH / SCREWDRIVER SET

CODE	MODEL	LIST £
060426	P-13	13.23

The P-13 combines a Phillips type screwdriver set and six wrenches. The tempered steel master handle has openings for each size wrench. Working leverage can be maximised by sliding the handle to the proper position on the 9" wrench. Compact case contains 9" wrenches 3/32"; 1/8"; 5/32"; 3/16"; 7/32"; 1/4". Hardened steel screwdriver tips Phillips #1; #2; #3. Master handle.



Surbiton: 020 8399 7151

BIT WRENCHES



These bit wrenches allow access where conventional screwdrivers and bit drivers fail to reach.

- 25° offset angle keeps your knuckles up and away from the work surface.
- Reverse direction with a flip of the reversing pawl.
- Knurled spinner wheel for finger tightening of fasteners.

CODE	MODEL	DESCRIPTION	LIST £
061630	60584	Set includes bit #1 and #2 Phillips, 1/4" and 9/32" slotted	15.79
061631	60585	Ratcheting driver wrench only	12.50
061632	60586	#1 Phillips bit (pack of 5)	3.96
061633	60587	#2 Phillips bit (pack of 5)	3.96
061634	60588	Small slotted bit (pack of 5)	3.96
061635	60589	Medium slotted bit (pack of 5)	3.96

BRITool REFRIG. SOCKET SET SPARES

CODE	MODEL	DESCRIPTION	LIST £
060326	NF108L	Socket set	264.81
060301	D72	Ratchet	32.19
060310	D93	Flexible extension	13.76
060306	D97	6" extension	11.85
060311	DRX187	3/16" square socket	11.53
060312	DRX219	7/32" square socket	11.53
060313	DRX250	1/4" square socket	11.53
060314	DRX312	5/16" square socket	11.53
060315	DRX375	3/8" square socket	11.53
060307	DRG-1	7/16" gland socket	11.53
060308	DRG-2	15/32" gland socket	11.53
060324	DRG-3	11/16" gland socket	11.53
060325	DRG-4	13/16" gland socket	12.53
060327	DRG-5	9/16" gland socket	12.52
060309	DRO-1	1/2" oval gland socket	12.74
060353	APDP	1/4" sq x 3/8" sq converter	9.01
060317	AB525	3/8" sq x 1/4" Whit socket	4.78
060318	AB600	3/8" sq x 5/16" Whit socket	0.00
060319	AB710	3/8" sq x 3/8" Whit socket	0.00
060320	AB437	3/8" sq x 7/16" A/F socket	4.10
060321	AB500	3/8" sq x 1/2" A/F socket	0.00
060322	AB562	3/8" sq x 9/16" A/F socket	0.00
060354	DPH4	1/8" plug for recessed head screws	0.00
060355	DPH5	5/32" plug for recessed head screws	0.00
060356	DPH6	3/16" plug for recessed head screws	0.00
060323	R1	1/4" X 3/16" 'T' bar socket	12.52

Edinburgh: 0131 659 5333

SERVICE TOOLS

SCREWDRIVERS



<u>CODE</u>	<u>DESCRIPTION</u>		<u>LIST £</u>
061570	Plain slot - flared	6mm x 100mm	3.55
061571	Plain slot - flared	8mm x 150mm	5.71
061572	Plain slot - flared	9.5mm x 200mm	7.49
061575	Plain slot - parallel	3.2mm x 75mm	2.41
061576	Plain slot - parallel	5mm x 100mm	3.37
061577	Plain slot - parallel	5mm x 150mm	3.58
061580	Cross slot	No 1 x 75mm	3.32
061581	Cross slot	No 2 x 100mm	4.09
061582	Cross slot	No 3 x 150mm	5.94
061585	PZ type	No 1 x 75mm	3.32
061586	PZ type	No 2 x 100mm	4.09
061587	PZ type	No 3 x 150mm	5.94

OIL PUMPS

MAX-FLOW™ DELUXE OIL PUMP

Improved for added reliability and a more powerful stroke, the Max-Flow™ deluxe oil pump is a high capacity unit for quick charging. Pumps 3.8 ounces or 112.38ml per stroke.



<u>CODE</u>	<u>MODEL</u>	<u>LIST £</u>
060428	77930 Max-Flow™ Deluxe Pump	98.79

MAX-FLOW™ COMBINATION OIL PUMP

With the Max-Flow™ pump you can smoothly pump oil into the compressor on the down stroke while the system is under pressure. This make pumping easier with a positive stroke. Pumps 2.6 ounces or 78ml per stroke.



<u>CODE</u>	<u>MODEL</u>	<u>LIST £</u>
060430	77940 Max-Flow™ Combination Pump	77.38

EXPANDO

The fast, thorough and economical way to remove mineral scale and sludge from inside water-cooled condenser tubes.

Expando attaches to a threaded rod which fits into an Expando handle or your electric drill. With a reaming action, the tough stainless steel blades scrape everywhere inside the tube, providing a free, unrestricted flow.

Virtually clogproof, this tool may be expanded or reduced in diameter to fit scale deposits - not just the tube.



<u>CODE</u>	<u>MODEL</u>	<u>DESCRIPTION</u>	<u>LIST £</u>
060860	E-5	5/16" to 3/8" head	19.98
060861	E-6	3/8" to 1/2" head	19.98
060862	E-8	1/2" to 5/8" head	19.98
060863	E-10	5/8" to 1" head	19.98
060864	E-16	1" to 2" head	41.18
060865	E-32	2" to 3" head	41.18
060866	EC-56	Coupling for E-5 & E-6	1.53
060867	EC-810	Coupling for E-8, E-10 & rods	1.53
060868	EC-16	Coupling for E-16	3.28
060870	EE-30	30" rod	3.80
060871	EE-48	48" rod	4.78
060872	EH-1	'T' bar handle	3.01

FIN COMBS

Straighten, separate and clean evaporator and condenser fins.



<u>CODE</u>	<u>MODEL</u>	<u>DESCRIPTION</u>	<u>LIST £</u>
060420	61171	6 in 1 tool for 8, 9, 10, 12, 14 & 15 fins per inch	9.48
060421	P-8	4, 5, 8 & 10 fins per inch	1.49
060422	P-9	9 & 15 fins per inch	1.49
060423	P-11	11 & 13 fins per inch	1.49
060424	P-12	6, 7, 12 & 14 fins per inch	1.49
060419	P-17	16 & 17 fins per inch	1.49
060438	T-200	Suits all sizes	6.95

SERVICE TOOLS - MANIFOLDS

ITE



2812-BPC

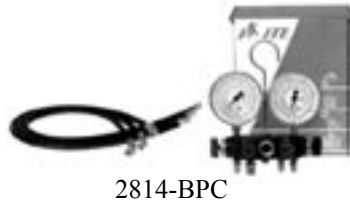

2814-BPC



2805-BPC

A range of 2, 4 and 5 valve manifolds incorporating a high density aluminium body, fitted with diaphragm leakproof soft seat valves and 80mm 'pulse-free' gauges.

<u>CODE</u>	<u>MODEL</u>	<u>VLV</u>	<u>CALIBRATION</u>	<u>LIST £</u>
060379	2812-BPC	2	R12; 22; 502/BAR/PSI/°C with 3 x 36" x 1/4" standard hoses	118.49
060380	2812-BC/447	2	R134A; 404A; 407C; 507/BAR/°C with 3 x 36" x 1/4" HD hoses	118.49
060378	2814-BPC	4	R12; 22; 502/BAR/PSI/°C with 3 x 60" x 1/4"; 1 x 60" x 3/8" standard hoses	171.32
060377	2814-BC/447	4	R134A; 404A; 407C; 507/BAR/°C with 3 x 60" x 1/4"; 1 x 60" x 3/8" HD hoses	171.32
060375	2805-BPC	5	R12; 22; 502/BAR/PSI/°C supplied without hoses	223.03
060376	2805-BC/447	5	R134A; 404A; 407C; 507/BAR/°C supplied without hoses	223.03
060373	84617-E		Plastic carrying case for all ITE manifolds	30.49

HD = heavy duty

YELLOW JACKET®



'41' SERIES

Forged brass body with metal handles.
2-1/2" diameter gauges.



'BANTAM'™

Aluminium bar with 3/8" vacuum port on 4-valve.
3-1/8" diameter gauges.



'BRUTE'™

Aluminium bar 3/8" bore with 3/8" vacuum port.
2-1/2" diameter gauges.

060365	41213	2	'41' R12; 22; 502/PSI/°F with 3 x 36" x 1/4" standard hoses	57.27
060366	41312	2	'41' R134A; 404A; 507/PSI/°F supplied without hoses	43.28
060368	41332	2	'41' R134A; 404A; 407C/PSI/BAR/°C supplied without hoses	46.98
061398	41769	2	'41' R410A/BAR/MPa/°C/°F with 3 x 72" x 1/4" hoses	86.81
061396	40193	2	'41' NH ₃ - AMMONIA/KG/CM ² /PSI/°C/°F with 3 x 48" x 1/4" hoses	246.03
060364	41343	2	'41' R134A/404A/507/PSI/°F with 3 x 60" x 1/2" ACME & 14mm fgs - automotive	120.30
060367	41417	4	'41' R12; 22; 502/PSI/°F with 3 x 36" x 1/4"; 1 x 48" x 3/8" standard hoses	115.35
061401	45836	2	'BANTAM'™ R134A; 404A; 407C/BAR/MPa/°C supplied without hoses	80.30
061402	45869	2	'BANTAM'™ R410A; BAR/PSI/°C supplied without hoses	82.51
061403	45936	4	'BANTAM'™ R134A; 404A; 407C/BAR/MPa/°C supplied without hoses	98.88
061404	45969	4	'BANTAM'™ R410A; BAR/PSI/°C supplied without hoses	102.01
061380	46212	2	'BRUTE'™ R12; 22; 502/PSI/°F supplied without hoses	83.43
061384	46340	2	'BRUTE'™ R134A; 404A; 507/PSI/°F supplied without hoses	84.76
061385	46332	2	'BRUTE'™ R134A; 404A; 407C/PSI/BAR/°C supplied without hoses	91.59
061388	46412	4	'BRUTE'™ R12; 22; 502/PSI/°F supplied without hoses	92.16
061392	46540	4	'BRUTE'™ R134A; 404A; 507/PSI/°F supplied without hoses	98.32
061393	46532	4	'BRUTE'™ R134A; 404A; 407C/PSI/BAR/°C supplied without hoses	102.48
060372	40263		Plastic carrying case for 41 series manifolds	24.10
060371	41112		Plastic carrying case for Brute™ series manifolds	32.68

SERVICE TOOLS - CHARGING HOSES

CHARGING HOSES

ITE

CODE	MODEL	SIZE	DESCRIPTION	LIST £
060409	E-336-FTR	1/4" x 36"	Red standard hose	8.47
060410	E-336-FTY	1/4" x 36"	Yellow standard hose	8.47
060412	E-336-FTB	1/4" x 36"	Blue standard hose	8.47
060411	E-303-FT-036	1/4" x 36"	Set of three standard hoses - red, yellow and blue	25.39
060440	E-360-FTR	1/4" x 60"	Red standard hose	11.28
060441	E-360-FTY	1/4" x 60"	Yellow standard hose	11.28
060442	E-360-FTB	1/4" x 60"	Blue standard hose	11.28
060443	E-560-FTY	3/8" x 60"	Yellow standard hose	27.11
060449	79583-01		ITE 1/4" replacement gasket	0.49



YELLOW JACKET®



060413	11983	1/4" x 36"	Set of three standard hoses - red, yellow and blue	21.15
061340	11036	1/4" x 36"	Yellow standard hose	7.06
061341	11236	1/4" x 36"	Blue standard hose	7.06
061342	11636	1/4" x 36"	Red standard hose	7.06
060414	11986	1/4" x 72"	Set of three standard hoses - red, yellow and blue	37.40
061343	11072	1/4" x 72"	Yellow standard hose	12.47
061344	11272	1/4" x 72"	Blue standard hose	12.47
061345	11672	1/4" x 72"	Red standard hose	12.47
061350	21983	1/4" x 36"	Set of three Plus II™ hoses - red, yellow and blue	28.59
061352	21986	1/4" x 72"	Set of three Plus II™ hoses - red, yellow and blue	43.47
061355	22983	1/4" x 36"	Set of three Plus II™ SealRight™ hoses - red, yellow and blue	46.21
061357	22986	1/4" x 72"	Set of three Plus II™ SealRight™ hoses - red, yellow and blue	61.08
061359	25980	1/4" x 9"	Set of three Plus II™ hoses with FlexFlow™ - red, yellow and blue	40.38
061360	25983	1/4" x 36"	Set of three Plus II™ hoses with FlexFlow™ - red, yellow and blue	70.47
061362	25986	1/4" x 72"	Set of three Plus II™ hoses with FlexFlow™ - red, yellow and blue	85.01
061361	29983	1/4" x 36"	Set of three Plus II™ hoses with ball valve ends - red, yellow and blue	72.92
061363	29986	1/4" x 72"	Set of three Plus II™ hoses with ball valve ends - red, yellow and blue	89.10
061508	21426	1/4" x 72"	Blue Plus II™ hose - R410A 1/4" x 5/16"	17.33
061509	21466	1/4" x 72"	Red Plus II™ hose - R410A 1/4" x 5/16"	17.33
061510	21072	1/4" x 72"	Yellow Plus II™ hose	16.37
061511	21272	1/4" x 72"	Blue Plus II™ hose	16.37
061512	21672	1/4" x 72"	Red Plus II™ hose	16.37
061364	14536	3/8" x 36"	Yellow Plus II™ -B hose	16.61
061366	14572	3/8" x 72"	Yellow Plus II™ -B hose	23.10
061365	15636	3/8" x 36"	Black heavy duty Plus II™ hose	20.70
061367	15672	3/8" x 72"	Black heavy duty Plus II™ hose	30.66
061370	19020/single		Yellow Jacket 1/4" replacement gasket	0.28
061371	19011/single		Yellow Jacket 3/8" replacement gasket	0.61
061372	19037/single		Yellow Jacket 1/4" replacement SealRight™ gasket	0.49
061375	93844		Yellow Jacket 1/4" flare ball valve M x F - straight	12.60
061376	93843		Yellow Jacket 1/4" flare ball valve M x F - 45° angle	13.53

- **PLUS II™** hoses have the proven performance benefits of the original hose, plus double barrier protection.
- **SEALRIGHT™** low loss anti blowback fitting immediately traps refrigerant in the hose when disconnected.
- **FLEXFLOW™** has a flexible hose between ball valve assembly and fitting.

SERVICE TOOLS - PRESSURE GAUGES

GAUGES



49001



49006



49076

49075

YELLOW JACKET®

<u>CODE</u>	<u>MODEL</u>	<u>SIZE</u>	<u>RANGE</u>		<u>BASE</u>	<u>CASE</u>	<u>CALIBRATION</u>	<u>LIST £</u>
			<u>COMPOUND</u>	<u>PRESSURE</u>	<u>CONN</u>			
060468	49001	2-1/2"		0-500 PSI	1/8" MPT RED		R12; 22; 502/PSI/°F	12.15
060469	49002	2-1/2"	30"-0-120 PSI		1/8" MPT BLUE		R12; 22; 502/PSI/°F	14.34
060484	49005	2-1/2"		0-500 PSI	1/8" MPT RED		R12; 22; 502/PSI/BAR/°C	13.81
060485	49006	2-1/2"	30"-0-120 PSI		1/8" MPT BLUE		R12; 22; 502/PSI/BAR/°C	16.01
060456	49051	2-1/2"		0-500 PSI	1/8" MPT RED		R134A; 507; 404A/PSI/°F	13.93
060457	49052	2-1/2"	30"-0-120 PSI		1/8" MPT BLUE		R134A; 507; 404A/PSI/°F	15.85
060458	49055	2-1/2"		0-500 PSI	1/8" MPT RED		R134A; 507; 404A/PSI/BAR/°C	15.60
060459	49056	2-1/2"	30"-0-120 PSI		1/8" MPT BLUE		R134A; 507; 404A/PSI/BAR/°C	17.52
060486	49063	2-1/2"		0-500 PSI	1/8" MPT RED		R134A; 404A; 407C/PSI/BAR/°C	14.30
060487	49064	2-1/2"	30"-0-120 PSI		1/8" MPT BLUE		R134A; 404A; 407C/PSI/BAR/°C	16.24
060488	49053	2-1/2"		0-55 BAR	1/8" MPT RED		R410A/BAR/MPa/°C/°F	13.33
060489	49054	2-1/2"	-1 / +21 BAR		1/8" MPT BLUE		R410A/BAR/MPa/°C/°F	15.69
061496	49163	3-1/8"		0-35 BAR	1/8" MPT RED		R134A; 404A; 407C/BAR/MPa/°C	18.16
061497	49164	3-1/8"	-1 / +8 BAR		1/8" MPT BLUE		R134A; 404A; 407C/BAR/MPa/°C	18.16
061498	49135	3-1/8"		0-55 BAR	1/8" MPT RED		R410A/BAR/PSI/°C	18.16
061499	49136	3-1/8"	-1 / +21 BAR		1/8" MPT BLUE		R410A/BAR/PSI/°C	18.16

LIQUID FILLED 80mm DIAMETER (7° OFFSET STEM)

061490	49085	3-1/8"		0-500 PSI	1/8" MPT RED		R12; 22; 502/PSI/BAR/°C	24.61
061491	49086	3-1/8"	30"-0-120 PSI		1/8" MPT BLUE		R12; 22; 502/PSI/BAR/°C	26.35
061492	49075	3-1/8"		0-500 PSI	1/8" MPT RED		R134A; 507; 404A/PSI/BAR/°C	24.61
061493	49076	3-1/8"	30"-0-120 PSI		1/8" MPT BLUE		R134A; 507; 404A/PSI/BAR/°C	26.35
061494	49173	3-1/8"		0-35 BAR	1/8" MPT RED		R134A; 507; 404A/BAR/MPa/°C	26.35
061495	49174	3-1/8"	-1 / +24 BAR		1/8" MPT BLUE		R134A; 507; 404A/BAR/MPa/°C	27.42

GAUGE BOOTS

<u>CODE</u>	<u>MODEL</u>	<u>DESCRIPTION</u>	<u>LIST £</u>
061405	49090	Pair of rubber protective gauge boots (red and blue) for standard 2-1/2" gauges	9.63



SERVICE TOOLS - GAUGES / CHARGERS

GAUGES



823-BPC



825-BC-447

ITE 80mm DIAMETER GAUGES

CODE	MODEL	RANGE		BASE	CASE	CALIBRATION	LIST £
		COMPOUND	PRESSURE	CONN			
060464	823-BPC		0 - 450 PSI	1/8" MPT RED		R12; 22; 502/BAR/PSI/°C	18.56
060465	825-BPC	30"-0-120 PSI		1/8" MPT BLUE		R12; 22; 502/BAR/PSI/°C	18.56
060473	823-BC/447		0 - 31 BAR	1/8" MPT RED		R134A; 404A; 407C; 507/BAR/	18.56
060474	825-BC/447	-1 / +8 BAR		1/8" MPT BLUE		°C	18.56
060476	PF-80V	0-1000 mBAR		1/8" MPT BLACK		R134A; 404A; 407C; 507/BAR/°C	41.08

SURFACE MOUNT 4" DIAMETER GAUGES - 1/4" FL BOTTOM CONNECTION

CODE	MODEL	RANGE		CALIBRATION	LIST £
		COMPOUND	PRESSURE		
060460	5013	30"-0-160 PSI		R12; 22; 502/PSI/°F	20.06
060461	5014		0-360 PSI	R12; 22; 502/PSI/°F	20.06
060462	5015	30"-0-160 PSI		R12; 22; 502/PSI/°F - LIQUID FILLED	39.56
060463	5016		0-360 PSI	R12; 22; 502/PSI/°F - LIQUID FILLED	39.56
060490	5213	-1 / +9 BAR		R12; 22; 502/BAR/°C	20.06
060491	5214		-1 / +24 BAR	R12; 22; 502/BAR/°C	20.06
060492	5215	-1 / +9 BAR		R12; 22; 502/BAR/°C - LIQUID FILLED	39.56
060493	5216		-1 / +24 BAR	R12; 22; 502/BAR/°C - LIQUID FILLED	39.56
060494	5223	-1 / +11 BAR		R22; 134A; 404A/BAR/°C	20.06
060495	5224		0 / +25 BAR	R22; 134A; 404A/BAR/°C	20.06
060498	5225	-1 / +11 BAR		R22; 134A; 404A/BAR/°C - LIQUID FILLED	39.56
060499	5226		0 / +25 BAR	R22; 134A; 404A/BAR/°C - LIQUID FILLED	39.56
060496	5118		0 / +10 BAR	OIL/BAR/PSI	20.06
060497	5119		0 / +10 BAR	OIL/BAR/PSI - LIQUID FILLED	39.56

CHARGING ADAPTERS

QUICK CHARGE

Quick Charge : 1/4" female flare (inlet) x 1/4" male flare (outlet).

Accepts liquid refrigerant from the cylinder and discharges directly into low side through charging manifold. Charging rate is up to 8 times faster than vapour charging.

CODE	DESCRIPTION	LIST £
060416	536-C16 Quick Charge	43.77



LIQUID CHARGING ADAPTER

CODE	MODEL	DESCRIPTION	LIST £
060900	41123	1/4" Liquid charging adapter	7.72
060901	41132	Replacement O-ring/orifice for 1/4" adapter	3.32



- To protect the compressor, adapter orifice reduces liquid flow to a level below compressor capacity.
- Refrigerant flashes off into a saturated vapour to speed entry.
- Eliminates the time and work of heating cylinders.
- Blue colour-coded aluminium.

SERVICE TOOLS / SOLDERS & FLUXES

CAP CHECK

The Thermal Cap-Check is a portable hydraulic unit used for cleaning refrigeration capillary tubes. The T1003 is supplied with a 0-500PSI gauge, a trigger operated gauge shut-off so that pressures in excess of 5000PSI will not damage the gauge, a 30" high pressure hydraulic hose with 1/4" male flare outlet which connects the capillary tube to the Cap-Check and an adapter to connect the capillary tube directly to the hose without a flare fitting.

<u>CODE</u>	<u>DESCRIPTION</u>	<u>LIST £</u>
060439	A10971 Capillary gauge with tube file	26.57
060431	T1102 Capillary gauge 10 different sizes	18.43
060432	T1003 Cap-Check	179.87
060433	T1056 Cap-Check rubbers (pack 12)	4.21
060434	Metal case for Cap-Check	23.73
060435	T1101 Chaser Kit	45.63

The Chaser Kit is a selection of 10 different sized spools of lead alloy wire which is used in conjunction with the Thermal Cap-Check to clear partially blocked capillary tubes.



SOLENOID VALVE OPERATING MAGNET

The Solenoid Magnet is the ideal tool for the service/maintenance engineer who requires the solenoid valve to be operated manually during installation, commissioning or when power is not available.



<u>CODE</u>	<u>DESCRIPTION</u>	<u>LIST £</u>
060540	Solenoid Magnet (white) to fit stem size of 10.5mm	20.52
060541	Solenoid Magnet (orange) to fit stem size of 15.5mm	20.52
060542	Solenoid Magnet (red) to fit stem size of 18mm	20.52

INSPECTION MIRROR



060766	M-2 2-1/2" telescopic inspection mirror extending 10" to 14"	10.49
060767	M-2R replacement mirror head	4.22
060768	ELD mirror and flashlight	17.05
060769	IMK3 2" telescopic mirror with magnet and clip attachment extending to 27"	13.04

SOLDERS, FLUXES & ABRASIVES

<u>CODE</u>	<u>DESCRIPTION</u>	<u>AG CONTENT</u>	<u>DIMENSIONS</u>	<u>MELT TEMP</u>	<u>LIST £</u>
060183	S2 Rolot - 1Kg pack	1.5 - 2.5%	2 x 2 x 500mm	710 - 820°C	42.46
060184	S5 Rolot - 1Kg pack	4 - 6%	2 x 2 x 500mm	710 - 820°C	83.43
060192	Phosbond 0	0%	3 x 500mm	710 - 810°C	1.07
060193	Phosbond 5	5%	1.5 x 500mm	645 - 815°C	0.76
060195	30T flux coated cadmium free silver solder	30%	1.5 x 500mm	650 - 750°C	3.62
060196	Silbond 2 silver solder	42%	1.5 x 500mm	610 - 670°C	3.70
060200	Phoson 1lb pack	0.5%	1 x 5 x 500mm	650 - 810°C	9.05
061140	SF-1 Silverflow - 1lb pack	0%	3 x 455mm	732 - 816°C	14.80
060189	Bridgit liquid flux - 4oz				4.06
060197	TA-1 powder flux - 500g				9.18
060201	TA-1 powder flux - 250g				5.17
060203	TA-1 tub paste flux - 250g				6.40
060207	CleanFit mini abrasive strips - medium grade 38mm x 250mm (pack of 10)				6.66
060208	CleanFit 5m abrasive roll - medium grade 38mm x 5m				11.61
060209	CleanTex mini abrasive pads - medium grade 50mm x 250mm (pack of 5)				5.01

BRAZING EQUIPMENT

HEAT MAT

Heat shield made from silicate fibre.

Short term use up to 1300°C - permanent resistance up to 1100°C

<u>CODE</u>	<u>MODEL</u>	<u>DESCRIPTION</u>	<u>LIST £</u>
-------------	--------------	--------------------	---------------

061185	78931	Solder heat mat	36.02
--------	-------	-----------------	-------

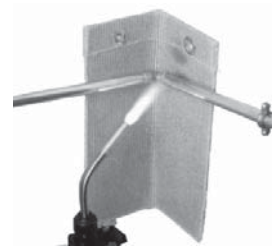

SCORPION 5300 KIT

The Scorpion 5300 Refrigeration Pack is a lightweight portable Oxy/Butane or Oxy/Propane kit ideal for the mobile engineer. Built to endure hard everyday use, this set is only 50 cms tall and is supplied with carrying frame, refillable oxygen cylinder with regulator, propane aerosol, control valve, 6000 torch and hoses, non return valves and a selection of nozzles. Capable of producing a 2760°C flame, this is ideal for brazing and silver soldering.

060169	5300	Refrigeration Pack	510.45
060170	55579	Oxygen cylinder and regulator assembly	376.12
060172	5000/400	Oxygen re-filling hose	80.60
060168	8908	Propane gas aerosol 400g	12.39
060174	6016	No. 6 single flame tip	9.09
060175	6020	No. 10 single flame tip	10.73
060176	6055	No. 5 twin flame tip	21.46
060177	6088	No. 8 twin flame tip	22.42
060167	8910	Propane control valve	21.64
060178	5556	Butane control valve	17.91
060179	7005-6	Hose pair, 1.5m red & blue c/w two single and one twin hose clamp	21.34
060180	6000	Weldmaster torch and hoses	94.78
060181	55547	Oxygen gauge	28.36
060182	6045	Non-return valves (pair)	64.46



ROXY 120L KIT

<u>CODE</u>	<u>DESCRIPTION</u>	<u>LIST £</u>
061120	120L Roxy brazing kit	255.37
061125	Oxygen cylinder	36.49
061126	Oxygen regulator	59.40
061127	Maxigas 400 cylinder 600ml	7.46

This compact and portable kit provides most of the features of oxy-acetylene brazing, light welding and precision engineering applications. The 120L kit includes 5 nozzles, 1 x 110bar oxygen cylinder, 1 x Maxigas 400 cylinder, hoses, regulators and accessories.



TURBO TORCH®



A range of hand torches with disposable gas cylinders, together with interchangeable tips and heat shields.

The TurboSnake Kit includes: STK-R regulator, ST-4 tip, TSH handle, hose assembly, MT-1 MAPP® gas cylinder and a stand.

<u>CODE</u>	<u>DESCRIPTION</u>	<u>LIST £</u>
061145	STK-9 regulator and tip	57.76
061146	TX504 piezzo ignition torch	69.40
061147	TS-1B TurboSnake Kit	134.33
061148	STK11 double barrel torch	76.42
061150	ST-1 tip	20.90
061152	ST-3 tip	30.64
061158	HS-5 heat shield (fits ST-1)	14.42
061160	HS-14 heat shield (fits ST-3)	14.42
061180	MT-1 MAPP® gas 16oz (yellow tank)	9.16
061181	PT-1 propane 14.1oz (red tank)	5.87

WEIGHING AND CHARGING SCALES

TIF

9010A Slimline Refrigerant Scale



A revised and updated version of the classic TIF Slimline scale, the new TIF9010A brings greater performance, reliability and usability to the trade.

- Touch key controls
- Displays lbs/oz and kg
- Very high resolution - 0.1oz / 2g
- 110 lbs / 50kg capacity
- Compact design, 2.5" (6.35cm) thick
- Completely portable - battery powered

<u>CODE</u>	<u>DESCRIPTION</u>	<u>LIST £</u>
060607	TIF9010A slimline refrigerant scale	256.14

9025 Electronic Charging/Recovery Meter



With a maximum weight capacity of 150 pounds (68kg) the TIF9025 will handle all but the heaviest containers. For those who want more than the TIF9010A the TIF9025 provides additional capacity.

- Measures refrigerant dispensed into system or cylinder
- Displays lbs/oz and kg
- Resolution - 0.5oz / 10g
- LCD readout
- Completely portable - battery powered

060609	TIF9025 electronic charging / recovery meter	348.26
--------	--	--------

9050I Programmable Charging/Recovery Meter



If you need the ability to automatically dispense an amount of refrigerant into an ACR system or cylinder, then the TIF9050I is for you. It responds instantly to programming commands and is completely automatic.

- Programmable - allows the user to preset amount for automatic charge / recovery
- Displays lbs/oz and kg
- Resolution - 0.5oz / 10g
- LCD readout
- Hold and Power Alert features
- Capacity 150 lbs/68 kg
- Power supply: battery and 230V/50Hz

060611	TIF9050I Programmable charging / recovery meter	477.61
--------	---	--------

9075 Dual Gas Charging/Recovery Meter



This Dual Solenoid Electronic Charging Meter allows you to quickly and efficiently charge non-compatible refrigerants (new and old refrigerants) without the chance of cross contamination. High resolution enables precise charging for optimum economy and system performance.

- Programmable - allows the user to preset amount for automatic charge / recovery
- Displays lbs/oz and kg
- Resolution - 0.5oz / 10g
- LCD readout
- Hold and Power Alert features
- Capacity 150 lbs/68 kg
- Power supply: battery and 230V/50Hz

060613	TIF9075ACR dual gas charging / recovery meter	594.61
--------	---	--------

CHARGING SCALES / ELECT SIGHT GLASS

ITE

WS-120: a high capacity (264 lb/120 kg) set of scales designed for both charging and recovery.

- Displays lbs/oz and kg
- Selectable resolution: 20g / 10g
- 264 lbs / 120kg capacity
- Completely portable - 9V battery powered

<u>CODE</u>	<u>DESCRIPTION</u>	<u>LIST £</u>
060591	WS-120 electronic charging / recovery scale	230.45



YELLOW JACKET®

The new Yellow Jacket 68810 Electronic Scale is totally self-contained. Open the lid of the rugged case and it's ready to go. Use it in the case or pull it out and set on a level surface.

- LCD readout
- Displays imperial and metric units
- Capacity 220 lbs/100 kg
- Resolution 0.1 oz/0.01 lb/0.01 kg
- Completely portable - battery powered

The Yellow Jacket 68811 programmable electronic charging scale has the same features as the 68810 with additional capabilities for automated, economical charging. Charging module hooks to scale with a coiled cord. Simple 3 button operation. Suitable for use with all refrigerants including R410A. Has a larger case.

060594	68810 Electronic charging scales	320.83
060595	68811 Programmable electronic charging scales	440.72
060596	68818 230V adapter for 68811	28.64



MASTERCool®

The new 'Smart Charge' scale does it all! Program and automatically transfer refrigerant to and from the A/C system. The capacity of over 700 models of cars from around the world is contained in the scale's memory. With the easy to use keypad you can retrieve almost any refrigerant capacity from automobiles made from 1989-up.

- Displays imperial and metric units
- Capacity 110 lb / 50kg or 176 lb / 80kg
- Resolution 0.2 lb / 10g @ 50kg or 0.4 lb / 20g @ 80kg capacity

060597	98300 Smart Charge - 220V	500.78
--------	---------------------------	--------



ELECTRONIC SIGHT GLASS

The TIF4000A 'sees' into the refrigerant tubing by means of ultrasonics. Two sensors are used, one for transmitting and one for receiving. The sensors are in the form of clamps which attach to any metallic refrigeration tubing. An audible beeping sound quickens as bubbles or floodback are sensed, and a row of LEDs light, simulating bubble movement in the tubing.

060605	TIF4000A Electronic sight glass	208.96
--------	---------------------------------	--------



LEAK DETECTORS / SPARES

TIF

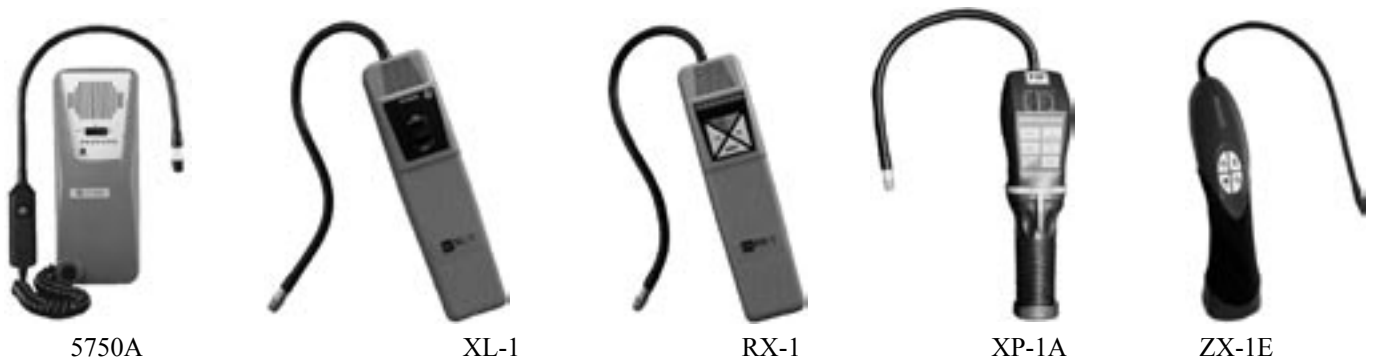

<u>CODE</u>	<u>DESCRIPTION</u>	<u>LIST £</u>
060517	TIF5750A offers a detachable, flexible hose with micro-pump, leak intensity indicators. It is battery powered and has ultimate sensitivity of 0.1oz/3gr per year.	268.00
060616	TIFXL-1 is battery operated, with the innovative MPC circuitry and Advanced Digital Signal Processing monitor the sensing tip up to 2000 times per second. Having single switch control it offers an ultimate sensitivity less than 0.4oz/11gr per year.	184.00
060617	TIFRX-1 offers all the above with the addition of a six segment indicator, mechanical pump, High and Low sensitivity to 0.25oz/7gr per year.	259.00
060618	TIFXP-1A has in addition to the above six-segment indicator displays, 18 alarm levels, mute feature and 7 levels of sensitivity to 0.1oz/3gr per year.	313.00
060619	TIFZX-1E utilises a Heated Pentode™ leak detector and has a tri-colour leak indicator, mechanical pump, sensor failure indication and ultimate sensitivity less than 0.1oz/3gr per year.	410.00



<u>CODE</u>	<u>DESCRIPTION</u>	<u>LIST £</u>
060506	TIFH10AI 230V/50Hz leak detector	228.70

This AC powered leak detector is ideal for continuous use and/or bench testing. It has a sensitivity adjustment knob for fine tuning. built in neon light and a unique probe with built in pump giving ultimate sensitivity to less than 0.1oz/3g per year.

TIF SPARES

<u>CODE</u>	<u>MODEL</u>	<u>TO SUIT</u>	<u>LIST £</u>
060527	TIF442 - tip protector	TIF5000	1.00
060510	TIF542 - tip protector	TIF5500/5600	1.00
060528	TIF543 - tip protector	TIF5050	1.99
060529	TIF556 - tip protector	TIF5550/5650	1.99
060523	TIF444 - maintenance kit	TIF5000	35.82
060522	TIF544 - maintenance kit	TIF5500/5600	35.82
060524	TIF554 - maintenance kit	TIF5050	35.82
060525	TIF555 - maintenance kit	TIF5550/5650/H10AI	35.82
060520	TIF573 - maintenance kit	TIF5750	35.82
060620	TIFXP-2 - maintenance kit	XL-1/RX-1/XP-1	40.30
060526	TIF560 - sensing tip	TIF5050/5550/5650/5750	9.95
060518	TIFZX-2 - sensing tip	ZX-1	56.00
060530	TIFZX-8 - replacement filters (pack 10)	ZX-1	5.75



LEAK DETECTORS / SPARES

YELLOW JACKET®

ACCUPROBE™ LEAK DETECTOR

	<u>CODE</u>	<u>DESCRIPTION</u>	<u>LIST £</u>
■ The AccuProbe™ leak detector with digital Smart Alarm™ measures, registers and digitally displays leak size. Leak source is located when numbers (1 to 9) stop increasing in LED.	060535	69366 AccuProbe™ leak detector with batteries and 230V AC adaptor	403.77
	060536	69383 Maintenance kit for above	47.08
	060537	69385 Pack of 5 replacement filters	4.46
■ Three sensitivity levels includes ultra-high to detect leaks as small as 0.06 oz/yr of R134a and 0.03 oz/yr of R22.			
■ Heated electromechanical sensor.			
■ Probe tip flashes to signal a leak.			
■ Audible beeping signals a leak and increases in frequency as the probe tip gets closer to the leak source (can be muted).			



COMBUSTIBLE GAS LEAK DETECTOR

Hand-held precision equipment detects all hydrocarbon and other combustible gases including propane, methane, butane, industrial solvents and more.

- Ultra-sensitive sensor detects less than 5 ppm methane and better than 2 ppm for propane. Performs equally well on a complete list of detectable gases including acetylene, butane and isobutane.
- Automatic calibration and zeroing.
- Long life sensor easily replaced after full service life.

<u>CODE</u>	<u>DESCRIPTION</u>	<u>LIST £</u>
062365	69373 Combustible gas leak detector	274.24
062366	69371 Replacement sensor for above	19.45



MICRO LED UV LEAK DETECTOR



Yellow Jacket® lightweight UV leak detector kits. The trend in UV lamp systems is toward smaller, lighter weight and easier to handle light sources. The Micro UV LED system is designed for AC&R and automotive applications. Press a button for constant or momentary light to spot leaks in any A/C system with just about any refrigerant. All the lamps are manufactured from aircraft aluminium body clad in Type III anodizing. Powered by a long life lithium cell, the 100,000+ hour LEDs are recessed for protection into a stainless steel head.

Kits 69789 and 69788 come complete with 69790 lamp, which is ideal for detecting leaks over a greater distance, disposable dye injector tube for two 1/2 oz. applications, injector hose and carrying pouch.

Lamp model 69791 is Pure UV™ with five UV bulbs. Lamp model 69792 is for general use, illuminating 120 feet away with five clear high intensity bulbs.

<u>CODE</u>	<u>MODEL</u>	<u>DESCRIPTION</u>	<u>LIST £</u>
062350	69789	Micro UV LED and dye kit for air conditioning and refrigeration	100.81
062351	69788	Micro UV LED and dye kit for automotive air conditioning	134.50
062352	69790	Micro UV LED lamp with 3 UV bulbs and 2 blue bulbs	61.72
062353	69791	Micro Pure UV™ LED lamp with 5 UV bulbs	62.85
062354	69792	Micro LED lamp with 5 clear bulbs for general use	60.60

Universal dye solutions. Universal dye for A/C and refrigeration systems with mineral, alkyl or polyolester lubricants.

062357	69710	60ml universal A/C dye	20.00
062358	69712	240ml universal A/C dye	95.47



LEAK DETECTORS / DYE

SPECTROLINE



A range of fluorescent leak detection kits suitable for use with refrigeration and air conditioning systems using HFC, CFC and HCFC refrigerants. Leaks will appear to glow under the ultra violet lamp once the Spectrolin dye has circulated around the system. An accurate method to pinpoint leaks, confirm repairs and perform preventative maintenance on small, medium and large applications.

<u>CODE</u>	<u>MODEL</u>	<u>DESCRIPTION</u>	<u>LIST £</u>
062200	TLK-100BZ/FB	Complete Spectrolin Starter Kit. 12v 100w lamp (TLK-100/FB), dye injector BEZ-50 & BEZ-25 and a cartridge of Universal dye for systems between 720ml and 23 litres of oil.	565.67
062202	TLK-100A/FB	TL100/12Titan UV/blue™ lamp 12v 100w, UVS-40 spectacles, carry case, sample of cleaner, rechargeable battery and battery charger.	446.27
062204	LD80SK/FB	240v BIB-150P/FB UV lamp (150w), 2.4 metre cord, UVG-50 spectacles, carry case and sample of cleaner.	530.87

SPECTROLINE GLO-STICK® CAPSULES (box of 6)

When using the selection chart, it is always advisable to calculate the volume of dye required based on the oil charge.

<u>REFRIGERANT</u>	<u>CAPSULE SIZE</u>	<u>OIL</u>
Up to 1.3kg of refrigerant	GS-101	Up to 0.4 litres of compressor oil
1.4 to 2.2kg of refrigerant	GS-1	0.5 to 1.5 litres of compressor oil
2.3 to 4.5kg of refrigerant	GS-2	1.6 to 3.0 litres of compressor oil
4.6 to 11.3kg of refrigerant	GS-3	3.1 to 7.6 litres of compressor oil

<u>CODE</u>	<u>MODEL</u>	<u>LIST £</u>	<u>CODE</u>	<u>MODEL</u>	<u>LIST £</u>
062211	GS-101/E (ester oil)	54.52	062225	GS-101/LT (alkyl benzene)	54.52
062212	GS-1/E	91.18	062226	GS-1/LT	91.18
062213	GS-2/E	126.90	062227	GS-2/LT	126.90
062214	GS-3/E	184.42	062228	GS-3/LT	184.42
062218	GS-101 (mineral oil)	48.58	062232	GS-101/PAG (PAG-automotive)	48.95
062219	GS-1	83.18	062233	GS-1/PAG	81.85
062220	GS-2	114.99	062234	GS-2/PAG	113.91
062221	GS-3	168.52	062235	GS-3/PAG	165.55

Capsules for ester lubricants are also compatible with mineral oil and alkyl benzene lubricants.

LEAK DETECTORS / SERVICE INSTRUMENTS

TURBO TORCH®

TT-LP flame type leak detector fits standard MT-1 MAPP® or PT-1 propane gas cylinders.

<u>CODE</u>	<u>DESCRIPTION</u>	<u>LIST £</u>
060475	TT-LP leak detector	62.69
061180	MT-1 MAPP® gas 16oz (yellow tank)	9.16
061181	PT-1 propane gas 14.1oz (red tank)	5.87



ROTHENBERGER

ROTEST Leak Detection Spray is a highly sensitive foam that seeks out leaks in pressurised pipes, pressure vessels and compressor systems. Non-reactive with any gases including oxygen and refrigerants and is ozone friendly. Simply spray on the area being checked and small bubbles or a foam will form, even with the slightest leak.

<u>CODE</u>	<u>DESCRIPTION</u>	<u>LIST £</u>
060483	Rotest Leak Detection Spray 400ml	8.66



TRACE 2® DETECTOR



Trace 2® is a tracer type red dye internal leak detector which pinpoints the exact leak location in refrigeration systems. Trace 2® is compatible and miscible with all CFC, HCFC, HFC refrigerants and all their lubricants - POE, PAO, PAG, AB and MO. Trace 2® is non-volatile and will not sludge or deposit gum. It is soluble in and travels with the lubricant.

- Temperature range: -37°C to +204°C
- Fluorescent with any ultraviolet light source

<u>CODE</u>	<u>DESCRIPTION</u>	<u>LIST £</u>
060477	Trace 2® dye 4oz bottle (118ml)	10.67
060478	Trace 2® dye 16oz bottle (470ml)	31.86

SOUND LEVEL METER



This battery operated, easy to use unit measures and displays 30-130db digitally and as an analogue graph to help you test for compliance, monitor equipment, and more.

- Six measurement ranges in 10db increments: 30-80; 40-90; 50-100; 60-110; 70-120; 80-130.
- Background noise filter and electric condenser microphone with foam wind screen for measurement accuracy.
- Easy to see 42 x 64mm backlit LCD.
- Max/Min and Max Hold functions.
- Low battery indicator.

<u>CODE</u>	<u>DESCRIPTION</u>	<u>LIST £</u>
060697	69346 Deluxe sound meter	300.25

TACHOMETER



Easy to use and read unit measures 10 to 99,999 RPM on compressors, fans, motors, gears, pulleys, and more. Non-contact reading maintains torque and precise measurement.

- Auto range function.
- Non-sleep mode and hold function.
- Measure and read with the press of a button.
- Low battery indicator.
- Units in RPM, M/Min, Ft/Min, Yd/Min.
- Hold function to freeze rotating speed.
- Reading to a resolution of 0.001 RPM.

<u>CODE</u>	<u>DESCRIPTION</u>	<u>LIST £</u>
060698	69348 Non-contact photo tachometer	139.24

SERVICE INSTRUMENTS

DIGITAL MULTIMETERS



YF-602



MX-505



MADMT3



MA12812

<u>CODE</u>	<u>MODEL</u>	<u>RESISTANCE</u>	<u>AC VOLTS</u>	<u>DC VOLTS</u>	<u>AC AMPS</u>	<u>DC AMPS</u>	<u>FEATURES</u>	<u>LIST £</u>
061321	YF-602	200ohm 2/20/200kohm 2/20Mohm	200/750	200mV 2/20/ 200/600V		2/20/ 200mA	Diode and transistor test. Continuity buzzer below 30ohm. Leads, battery, stand and instructions.	29.85
061322	MX-505	200ohm 2/20/200kohm 2/20Mohm	200mV 2/20/ 200/750V	200mV 2/20/200/ 1000V	200µA 20/200mA 10A	200µA 20/200 mA	Leads, temperature probe, battery, stand, case and instructions, continuity buzzer and diode test, temperature 0 to 1999°F -20 to 1370°C.	82.09
061323	MADMT3	200/2000ohm 20/200/ 2000kohm	200/750V	200/2000 mV 20/200/ 1000V		2000µA 20/200 mA 10A	Compact design, fuse protected, temperature -58 to +2498°F -50 to +1370°C, K-type probe, audible continuity, 3-1/2" digital display, battery and leads.	19.99
061324	MA12812	400ohm to 40Mohm auto range	400 mV to 750V auto range except 400mV	400mV to 1000V auto range	400µA to 10A auto range for µA and mA	400µA to 10A auto range for µA and mA	Audible continuity, temperature -4 to +1400°F -20 to +760°C, capacitance, relative zero button, frequency current, battery and leads.	47.09

<u>CODE</u>	<u>DESCRIPTION</u>	<u>LIST £</u>
-------------	--------------------	---------------

061326	MA12817/CS Big Digital Multimeter	64.85
--------	-----------------------------------	-------



AC VOLTAGE	2/20/200/700V
DC VOLTAGE	200mV/2/20/200/1000V
AC AMPS	2/200mA/20A
DC AMPS	2/20/200mA/20A
RESISTANCE	200 Ohm/2/20/200kOhm/2/20MOhm
TEMPERATURE	-50°C to +1370°C / -58°F to 2498°F

Back lit, auto power off and data hold.

Mechanical doors which open and close when turning dial to prevent incorrect lead connection.

SERVICE INSTRUMENTS

DIGITAL CLAMP METERS



YF-8030



TM-12E



YF-8050



MA12820

<u>CODE</u>	<u>MODEL</u>	<u>RESISTANCE</u>	<u>AC VOLTS</u>	<u>DC VOLTS</u>	<u>AC AMPS</u>	<u>DC AMPS</u>	<u>FEATURES</u>	<u>LIST £</u>
061328	YF-8030	400ohm, 4/40/400kohm, 4/40Mohm	4/40/ 400/750V	400mV 4/40/ 400/1000V	400/ 1200A	400/ 1200A	Data hold, low battery and over range displays and zero adjust. Continuity buzzer. Case, leads, battery and instructions. Jaw size 53mm.	191.04
061329	TM-12E	400ohm 4-40kohm 40Mohm auto range	400/600V auto range	400/600V auto range	40/400A		Overload protection and data hold. Case, leads, battery and instructions. Jaw size 30mm.	100.00
061330	YF-8050	4kohm	400/750V		40/400/ 1000A		Peak hold, low battery and over range displays. Case, leads, battery and instructions. Jaw size 52mm.	116.42
061331	MA12820	400ohm 4/40/400kohm 4/40Mohm	4/40/400/ 600V auto range	4/40 400/600V auto range	400/600A	400/ 600A	Data hold, peak hold, DC current zero adjust, auto power off, 32mm jaw opening, case, battery, temperature -4 to 1400°F -20 to 760°C and capacitance ranges.	110.70

5 IN 1 DIGITAL METER

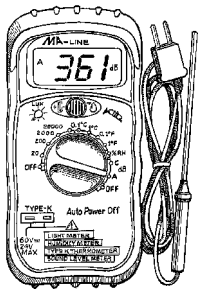

<u>CODE</u>	<u>DESCRIPTION</u>	<u>LIST £</u>
061334	MA12832 5 in 1 digital meter - sound, lux, humidity, temperature, AC/DC voltage	67.43

Features

- 3-1/2" large LCD display
- Auto power off
- K-type thermocouple
- 9V battery

Specifications

Temperature range	-58 to +2000°F
	-50 to +1300°C
Sound level	35db to 100db
Humidity	25% to 95% RH
Light (lux)	0.01 to 20000 lux

SERVICE INSTRUMENTS

SUPCO TEMPERATURE RECORDERS

The Supco CR87B Temperature Recorder with remote sensor employs advanced microcontroller design that enables this versatile instrument to accurately measure and record temperatures in air, gas, liquids, powders, solids and semi-solids. Recordings can be made from any distance up to 100 feet away by using an optional long length sensor wire. Two selector switches located on the face panel allow for the recording of 3 different temperature ranges at 4 different recording speeds.

Temp. scale selectable: -40°C to 0°C; -30°C to +10°C; +10°C to +50°C
 Chart speed selectable: 6hrs; 24hrs; 7days; 31days
 Primary power supply: 220-240VAC 50/60Hz
 Alternative power: 12V vehicle operation with optional adapter
 Battery backup: 8x AA alkaline batteries (not included)

<u>CODE</u>	<u>TYPE</u>	<u>LIST £</u>
060815	CR87B-220C Temperature recorder	401.98
060846	CR87-17 7-day recorder charts (-30/+10°C)	22.11



The SD50C7X ambient temperature recorder is a one range single pen recorder which can be placed directly into the environment that you need to measure and record. It is calibrated to record over 7 days within a temperature range of -30°C to +50°C and is operated by either 220VAC or 9V battery (not included). This portable, wall-mountable or freestanding unit features an ON/OFF switch, blinking 'ON' light, low battery indicator, 6" circular chart, replaceable pen and a large, easy to read LCD display.

060825	SD50C7X Ambient chart recorder	313.43
--------	--------------------------------	--------



SUPCO TEMPERATURE/HUMIDITY RECORDER

The CRTH2, with advanced microcontroller design for reliable operation, is a temperature, humidity and dew point recorder. These Elite series recorders feature 9 combined speed and temperature ranges and 15' remote probe. Power can be supplied by 220VAC and 12V vehicle or marine with 48hr battery backup.

Recording speeds: 12hrs; 24hrs; 7 days
 Temperature ranges: -30°C to +50°C; -30°C to +10°C; +5°C to +45°C

060820	CRTH2-220 Temperature/humidity recorder	583.33
--------	---	--------



SUPCO SERVICE LOGGER

This dual channel hand held digital logger connects with any one of five probes. Choose from recording speeds of 5 hours to 40 days. View data instantly or print data without the need of a computer. Simply connect to virtually any parallel printer. Optional accessory probes customise instrument to fit every application.

- Primary power source: 220-240V 50/60Hz
- Backup power source: 9V alkaline battery (not included)
- Alternate power source: External power may be supplied from any 12VDC source such as automotive or marine or other battery
- Temperature range: 0°C to +65°C
- Alpha numeric backlit display

060830	SL4-220 Service Logger	350.87
060832	KTH Combination temperature / humidity probe	188.06
060833	KTP Temperature and pressure probes	324.46
060834	KPP Dual pressure probes	602.56
060835	KTE Temperature and voltage event probes	188.06
060836	KTT Two temperature probes	188.06



SERVICE INSTRUMENTS

SUPCO DATA LOGGER

Supco's new easy to use **SL200C** data logger is a self-contained instrument designed to record the temperature of the surrounding environment.

- Windows 95, 98, 2000, NT and ME compatible
- PC or push button recording control
- Temperature alarm with visual indication on demand
- User selectable stop on memory full or memory rollover for continuous recording
- View graph and text simultaneously
- Can calibrate in the field
- Displays temperature in °F or °C
- No special cable required
- Temperature range: -40°C to +85°C (-40°F to +185°F)
- Temperature resolution: +/-0.5°C (+/-1°F)
- Temperature accuracy: +/-0.5°C (+/-1°F)
- Real time clock: Seconds; minutes; hours; date; month; day of week
- Memory: 2048 temperature samples
- Sampling rate: 1 to 255 minutes
- Alarms: High and low temperature alarms with visual indication on demand



<u>CODE</u>	<u>MODEL</u>	<u>LIST £</u>
061020	SL200C Temperature data logger & software	73.05

THERMOMETERS



- DT-1620** Hand held and pocket digital thermometer.
- Temperature range: -55°C to +149°C
-67°F to +300°F
 - 1 metre cable
 - 100mm stainless steel probe with tip protector

<u>CODE</u>	<u>MODEL</u>	<u>LIST £</u>
060694	DT-1620 thermometer	36.46



- ST09** Digital pocket thermometer
- Temperature range: -40°C to +200°C
-40°F to +392°F
 - ON/OFF; max/min; °C/°F; data hold switches
 - Water resistant

<u>CODE</u>	<u>MODEL</u>	<u>LIST £</u>
060691	ST09 thermometer	21.77



- PT100** Digital pocket surface thermometer.
- Ultra sensitive air and surface reading probe
 - Large LCD display 7/16" high, 3.5 digits
 - Battery operated requiring 9V battery
 - Hold switch to keep readings fixed
 - Temperature range: -40°C to +93.28°C

<u>CODE</u>	<u>MODEL</u>	<u>LIST £</u>
060690	PT-100C thermometer	77.45

The **LIT8LT** laser infrared wide range thermometer offers precise, non-contact measurement in a lightweight hand-held instrument. With its one hand operation, this unit is ideal for a wide variety of applications.



- Measuring Range: -50°C to +500°C
(-58°F to 932°F)
- Resolution: 1°C/F
- Distance Factor: D:S = approximately 8:1
- Accuracy: ±2% of reading or ±2°C/F
- Display: LCD with backlight
- Power Off: automatic shut off
- Power Supply: 9-volt battery (included)

<u>CODE</u>	<u>MODEL</u>	<u>LIST £</u>
060692	LIT8LT Laser infrared thermometer	124.00

SERVICE INSTRUMENTS

THERMOMETERS

COMARK



KM330 is a Type K thermocouple single point thermometer with a protective rubber boot and desk stand. 0.1° or 1° resolution. **KM340** is a twin point differential temperature version of KM330. 1° resolution. Supplied without probe.

- Scales: °C or °F
- Range: -50°C to +1300°C

KM450S is a general purpose Type K thermocouple single point thermometer. Supplied without probe.

- Scale: °C
- Range: -50°C to +800°C
- Resolution: 0.1°C to +200°C, 1°C above

<u>CODE</u>	<u>MODEL</u>	<u>LIST £</u>
060921	KM330 thermometer	105.97
060922	KM340 thermometer	123.88

<u>CODE</u>	<u>MODEL</u>	<u>LIST £</u>
060923	KM450S thermometer	186.57



KM220 is a pocket size thermistor thermometer with max/min and hold plus a PX21B detachable penetration probe.

- Scales: °C or °F
- Range: -40°C to +150°C



Pocketherm is a safe and convenient thermometer with integral folding probe. Instant visual indication of correct frozen, chilled and cooked temperature zones, plus compact design to fit your pocket or bag.

- Scale: °C
- Range: -40°C to +125°C

<u>CODE</u>	<u>MODEL</u>	<u>LIST £</u>
060918	KM220 compact thermometer	98.51

<u>CODE</u>	<u>MODEL</u>	<u>LIST £</u>
060919	P125 pocket thermometer	74.61

COMARK K TYPE PROBES

This professional range of type K thermocouple probes offers great value for money for general industrial, heating, ventilation, air conditioning and refrigeration probes.

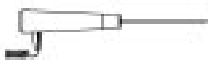

PRO-1



PRO-2



PRO-3

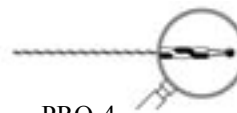

PRO-4



PRO-7

<u>CODE</u>	<u>MODEL</u>	<u>DESCRIPTION</u>	<u>LIST £</u>
060944	PRO-1	Penetration probe, maximum temperature +250°C	29.85
060950	PRO-2	Surface probe, maximum temperature +250°C	31.34
060941	PRO-3	Air / liquid probe, maximum temperature +250°C	29.85
060947	PRO-4	General purpose flexible air probe, maximum temperature +250°C	8.58
060938	PRO-7	Velcro strap probe for pipes, maximum temperature +100°C	30.60

SERVICE INSTRUMENTS

MEGOHMMETER

Specifically designed as an inexpensive alternative to taut band (swing needle) megohmmeters. This reliable battery operated instrument features LED indicators, and will accurately measure insulation values up to 1000 megohms at 500 VAC and also indicate the condition of the insulation on the zone scale.



<u>CODE</u>	<u>MODEL</u>	<u>LIST £</u>
060685	M500 insulation tester	155.40

CAPACITOR TESTER

This pocket size battery powered capacitor tester is simple to operate. Just attach the clips to the capacitor terminals, press the button and the exact capacitor value is brightly displayed on the LED readout and measures the capacitance value on start and run capacitors between 0.01 and 10000mfd. The test clips store within the durable case.



060555	MFD-10 capacitor tester	105.52
--------	-------------------------	--------

DIGITAL AIR FLOW METER



KM4007



DAM1



TIFVA105INT

KM4007 is a combined air flow meter and type K thermocouple thermometer with fixed probe.

Scales:	m/s, °C
Air flow:	0 to 30 m/s, 0 to +40°C
Temperature:	-10°C to +70°C
Resolution:	0.1m/s, 0.1°C

060935	KM4007 Digital air flow meter	373.13
--------	-------------------------------	--------

DAM1 Digital air flow meter displays FPM/MPH/KPH KNOTS/ MPS/CFM. It has a large LCD display, battery operation, measures temperature in °F/°C, data hold feature, MIN/MAX, multi point average and auto power off.

Air flow:	80-6900 FPM
Temperature:	-10°C to +50°C, +14°F to +122°F
Resolution:	1.0 FPM, 1.0°C, 2°F

060910	DAM1 Digital air flow meter	239.32
--------	-----------------------------	--------

A quick and easy to use balancing device, the **TIFVA105INT** provides true average readings on most grills and/or diffusers.

Scales:	ltr/sec; cm/sec	
060637	TIFVA105INT air flow meter	164.66

HERMETIC COMPRESSOR ANALYSER



The **2001** hermetic compressor analyser is used to test all single phase compressors up to 5HP, 110, 220 or 277 volts. Tied-up compressors may be freed by reversing motor rotation. The 2001 tests windings for opens, continuity and grounds. Tests start and run capacitors and system relays by substitution. Measures running amps, 0 to 10, 50A ranges. Measures start and run volts, 0-150, 600VAC ranges.

060573	2001 Hermetic compressor analyser	606.95
--------	-----------------------------------	--------

TEST & REPAIR KITS / CHEMICALS

ACID TEST KITS & NEUTRALISERS



Acid Away compressor burnout acid neutraliser removes acid from refrigeration systems.

<u>CODE</u>	<u>DESCRIPTION</u>	<u>LIST £</u>
060547	Sporlan AK-3 acid test kit with all solutions and bottles, supplied in a small, sturdy fitted case	150.78
060549	Sporlan TA-1 TEST-ALL one-time test kit for both mineral and polyolester oils	14.98
060550	AK1-16 indicator solution for AK-3 sets	12.36
060551	AKN-2 neutraliser solution for AK-3 set	14.67
060548	TKO Virginia one-bottle test kit - mineral oil	6.53
060543	ETK Virginia one-bottle test kit - polyolester oil	15.71
060801	Acid Away mineral oil version 118ml	33.30
060802	Acid Away POE oil version 118ml	36.17

EVAPORATOR REPAIR KITS



060198	HEAT-SEAL STICK, suitable for use on metals, ceramics, glass and seals refrigeration systems. Melts and cures in one operation. Heat repair area and apply Heat-Seal Stick	9.38
060199	DP-2 SUPER POXEE, an all purpose epoxy repair kit, suitable for bonding aluminium, copper, stainless steel and for sealing evaporator leaks. No external heat required	5.53



MO98



MO44



GreaseGobbler



PyroCool



Thawzone

CHEMICALS

<u>CODE</u>	<u>DESCRIPTION</u>	<u>LIST £</u>
060777	MO98 multipurpose SUPER TURBINE OIL is a paraffin base, non-gumming, high quality lubricating oil that withstands high temperatures without breaking down. 4oz bottle.	1.57
060779	MO44 RUST CUTTER SOLVENT loosens rust in seconds leaving no lingering odour. 4oz bottle.	1.57
061240	GreaseGobbler has been formulated to provide a quick and easy to use heavy duty solvent cleaner capable of cleaning away grease and dirt. GreaseGobbler condenser cleaner 400ml aerosol.	8.41
061242	PyroCool heat dissipating flame retardant gel 1litre. Protects all surfaces during soldering, brazing and welding.	15.54

Thawzone is a chemical 'drier' for all refrigerants CFC, HCFC, HFC as well as for all systems containing methyl chloride and methylene chloride. Thawzone frees systems frozen due to moisture in 5 minutes. It prevents refreezing, does not contain any residue, dissolved solids or methanol, and works with or without molecular sieve or ceramic core driers. Temperature range -73°C (-100°F) to +65°C (+150°F).

<u>CODE</u>	<u>DESCRIPTION</u>	<u>LIST £</u>
060773	Thawzone 4oz bottle (118ml)	8.55

CHEMICAL CLEANERS AND PROTECTION

BIOCIDE TABLETS

Designed to reduce odours by eliminating slime bacteria waste in air conditioning and commercial refrigeration units. Contains no foam detergent. Inhibits corrosion in drain pan.



<u>CODE</u>	<u>DESCRIPTION</u>	<u>LIST £</u>
061210	FT/C Anti Clog Tablet (air conditioning units up to 18kw)	5.51
061211	AT/C Anti Clog Tablet (air conditioning units 18kw to 57kw)	13.93

SMELLY JELLY

Odour neutralising product. Fragranced strips for fan coil and cassette units. Mounted with fixing hooks.



061203	Floral fragranced Smelly Jelly (red) - size 1	6.31
061204	Morning fragranced Smelly Jelly (white) - size 1	6.31
061205	Citrus fragranced Smelly Jelly (yellow) - size 1	6.31
061206	Herbal fragranced Smelly Jelly (green) - size 1	6.31
061207	Mountain fresh fragranced Smelly Jelly (blue) - size 1	6.31
061208	Single fixing hook for Smelly Jelly	0.18

ICE MACHINE CLEANERS

Metal Safe ice machine cleaner removes the normal limescale formulations which develop on ice machines. It is safe to use on nickel and tin plated evaporators.



061200	H420 0.25 ltr Metal Safe ice machine cleaner	4.68
061201	H421 3.78 ltr Metal Safe ice machine cleaner	41.43



HB30 liquid ice machine cleaner is safe for all types of ice machine including those with aluminium or nickel parts.

061267	HB30 ice machine descaler 1 ltr	10.09
061268	HB30 ice machine descaler 5 ltr	33.80

INTERNAL FLUSHING AGENT

061247	CF20 / EndoFlush is designed to be used as a flushing product for refrigeration systems. 5 ltr.	94.83
061249	Flushing pump 240V for use with above. (Also available for hire. Please call for details.)	675.22



COIL PROTECTION

ProTect acrylic polymer coating for all refrigeration and air conditioning coils. Specially formulated to provide coils with protection from corrosion caused by acid rain, saline atmospheres and corrosive environments.



061293	Easycoat - 500ml aerosol	8.41
061294	ProTect - 1 ltr sprayer	58.58
061295	ProTect - 5 ltr container	146.27

RTU READY TO USE / EASY TO USE COIL CLEANERS

061290	RTU evaporator cleaner - 1ltr spray can	12.37
061291	RTU evaporator cleaner and disinfectant - 1ltr spray can	12.37
061292	RTU condenser cleaner - 1ltr spray can	12.37
061296	Easyclean evaporator and condenser cleaner - 500ml aerosol	8.41
061297	Easycare evaporator cleaner with disinfectant - 500ml aerosol	8.41
061298	Easyfoam non acid foaming condenser cleaner - 500ml aerosol	8.41
061299	Easyfinish case and diffuser cleaner - 500ml aerosol	8.41



CHEMICAL CLEANERS AND PROTECTION

FRIONETT® CLEANING PRODUCT RANGES

	CLEANING	DEGREASING	OXIDATION REMOVAL	SANITISING DEODORISING BACTERICIDE FUNGICIDE VIRUCIDE
LIQUIDS	FRIONETT® 2 FRIONETT® 2 RTU	FRIONETT® 2 FRIONETT® 2 RTU	FRIONETT® 1 (OUTDOOR USE ONLY)	FRIONETT® 2 (CONDENSATE RINSEABLE)
AEROSOLS	FRIONETT® 360 SPRAY	FRIOSOLV SPRAY		FRIONETT® GERM FRIONETT® CLIM FRIONETT® 360 SPRAY
'SOLIDS' ANTI-MICROBIAL				PAN STRIPS

CODE PRODUCT DESCRIPTION LIST £



061215 FRIONETT PAN STRIPS Box of 12 x 14g strips for condensate drain, pan or catch basin. Avoid microbial, bacteria (Legionella), mould, slime, algae or viruses growth. Anti-corrosive. Refreshes and sanitises up to six months. 77.24



061216 FRIONETT 1 Powerful concentrated liquid coil cleaning foam, acid based - 3.8 litre. Corrosive. Eliminates rust particles. Restores efficiency. Mainly for outside condenser use. 25.06

061217 FRIONETT 2 Powerful concentrated liquid coil cleaning foam, alkaline based for routine maintenance - 3.8 litre. Non-corrosive. Non-flammable. Water based. Restores efficiency. Biodegradable. Bactericide, fungicide and deodorises. Outdoor and indoor use - condensers and evaporators. 20.15



061218 FRIONETT 2 RTU Ready to use liquid coil cleaning foam, alkaline based for routine maintenance - 0.95 litre. Non-corrosive. Non-flammable. Water based. Restores efficiency. Biodegradable. Bactericide, fungicide and deodorises. Outdoor and indoor use - condensers and evaporators. 12.96



061219 FRIONETT 360 SPRAY Heavy duty cleaning foam - 500ml. Anti-corrosion. Fungicide. Bactericide. Deodorising. Self (condensate) rinseable. Non-flammable. 12.96

061220 FRIOSOLV SPRAY Fast evaporating degreaser spray - 350ml. No need to rinse. Non conductive. Non-flammable. 10.97













061221 FRIONETT CLIM Heater and air conditioner treatment spray - 170ml. Powerful cleaning and sanitising active foam spray. Long lasting. Disinfects, deodorises and sanitises. Fresh citrus scent. Non-flammable. 12.88

061222 FRIONETT GERM Surface disinfectant for hard, non-porous surfaces and ventilation ducts - 500ml. Fogger type light spray. Deodorises. Non-flammable. 15.33

CHEMICAL CLEANERS / TUBE ADAPTERS

CHEMICAL CLEANERS

	<u>CODE</u>	<u>DESCRIPTION</u>	<u>LIST £</u>
	061250	HydroCoil heavy duty evaporator coil cleaner - 5ltr. A concentrated cleaner that is simple and effective in cleaning evaporator coils.	32.53
	061253	HydroFoam heavy duty foaming condenser cleaner - 5ltr. Developed specifically for air cooled condensers, it foams out stubborn deposits, even those which have become baked on.	34.91
	061259	HydroKleen non-acid condenser cleaner - 5ltr. The perfect solution to dirty or greasy air conditioning or refrigeration systems.	35.50
	061254	EnviroCoil eco-friendly coil cleaner - 5ltr. The environmentally friendly coil cleaner that attacks only dirt deposits, not equipment.	34.34
	061256	CondensCide coil and tray cleaner - 5ltr. This easy to use formulation cleans and disinfects metal services, eliminates slime in condensate trays and retards further dirt accumulation.	39.00
	061281	StayClean bacterial control treatment pack contains PreClean, StayClean and StayClean strips. Prevents the build-up of microbiological growth and removes offensive smells.	111.97
	061282	Hydrox safe scale remover - 5ltr. Ideal for online cleaning in open recirculating water systems, such as cooling towers and water cooled condensers, removing scale and slime.	54.27
	061284	DrainKleen condensate drain cleaner - 5ltr. A powerful and effective liquid drain cleaner, formulated especially to clear organic blockages in condensate drains.	50.55
	061285	Super HD Cleaner heavy duty cleaner - 5ltr. A powerful cleaner which removes oil, soot, grime, tobacco tars, carbon and sticky dust from refrigeration and air conditioning equipment as well as electrostatic and electronic air cleaners.	34.13
	061287	AntiGlo UV Fluorescent additive remover - 250ml. An essential product for any engineer who is using UV fluorescent leak detection. This safe, easy to use cleaner quickly sprays away fluorescent additive, allowing easy inspection to ensure that repairs have been made correctly.	8.41
	061286	HydroSprayer cleaner applicator. An extremely versatile low pressure sprayer, easily disassembled for cleaning.	85.06

PROCESS TUBE ADAPTERS





Offers a convenient method of making a service connection to a hermetic unit. Also ideal for providing a connection in testing coils, tubing installations etc. Handles pressure to 7 bar. To connect a hermetic system, pinched-off tube is cut off and adapter is slipped over cut end of tube and tightened. Synthetic rubber seal of adapter grips outside of tube. This gives a 1/4" male flare connection to the system for purging, charging or testing. After system is recharged, tube is pinched-off next to adapter. Adapter is then removed and tube is cut off and sealed with solder. Adapter can be reused repeatedly.

<u>CODE</u>	<u>MODEL</u>	<u>PIPE SIZE</u>	<u>LIST £</u>
060346	241-F-03	3/16"	32.10
060347	241-F-04	1/4"	20.08
060348	241-F-05	5/16"	37.35
060349	241-F-06	3/8"	23.71





COUPLERS / FITTINGS / LINE TAPS

QUICK CONNECT COUPLERS

	16C	The easy push/pull operation automatically opens or closes system without loss of refrigerant.	
	17C	CODE	MODEL
		060362	16-C Straight quick connector 1/4" male x female flare
		060363	17-C Elbow quick connector 1/4" male x female flare
			LIST £
			23.52
			31.25
	19090	Snaps on over 1/4" flare threads with Schrader cores. Forms tight connection immediately. Instantly activates Schrader in access fitting.	
		060357	19090 'Snap-It' TM quick coupler
			43.30
	10468A	Quick coupler, knurled knob, hand tightening connection, 1/4" flare with valve core depressor.	
		060352	5021 1/4" female flare x 1/4" male flare straight quick coupler
		060358	5022 1/4" female flare x 1/4" male flare 90° quick coupler
		060359	10468A 3/16" female flare x 1/4" male flare straight coupler
		060360	19173 5/16" female flare x 1/4" male flare 45° quick coupler (R410a)
			2.64
			3.17
			8.96
			9.00

AUTOMOTIVE SERVICE COUPLERS - R134A

	TIF9325	060780	TIF9325 High side 14mm acme fitting auto coupler	44.78
		060781	TIF9330 Low side 14mm acme fitting auto coupler	44.78
		060785	253A High side coupler with 1/4" x 14mm and 3/8" x 14mm adapters	50.19
		060786	254A Low side coupler with 1/4" x 14mm and 3/8" x 14mm adapters	50.19
	253A	060669	19161 1/2" male acme x 1/4" female flare adapter	8.58
		060670	19160 1/2" male acme x 1/2" female flare adapter	8.58
	19161	060671	19157 14mm male acme x 1/4" male flare adapter	8.58
		060672	19156 14mm male acme x 3/8" male flare adapter	11.41



LINE TAPS

AP-1 & AP-2: Adjustable valves supplied with T handle
 CV-1G: Standard control valve with single port used with LT's
 CV-2G: Double port control valve used with LT'S
 LT's: Range of single sized line tap valves

When installed, the gasket actually compresses the copper tubing 0.020" creating a 'Permanent' leakproof seal. Hex key wrench included - no additional tools required. Precision piercing needle is engineered for concentricity and hardness to ensure perfect seating every time.

CODE	MODEL	PIPE SIZE	LIST £
060336	AP-1	3/16", 1/4", 5/16", 3/8"	5.86
060337	AP-2	3/8", 1/2", 5/8"	6.45
060338	CV-1G	Control valve	8.03
060339	CV-2G	Control valve	11.11
060340	LT-3G	3/16"	3.58
060341	LT-4G	1/4"	3.43
060342	LT-5G	5/16"	3.45
060343	LT-6G	3/8"	3.51
060344	LT-8G	1/2"	3.64
060345	LT-10G	5/8"	3.71

CODE	MODEL	PIPE SIZE	LIST £
061000	BPV-31	1/4", 5/16", 3/8"	3.55
061001	BPV-21	1/2", 5/8"	3.93

ACCESS FITTINGS

Recommended for their low cost and easy adaption of refrigerant systems, these access fittings can be used for charging, pressure testing and purging. All fittings have 1/4" male flare access ports and are supplied complete with Quick Caps and cores.

<u>CODE</u>	<u>MODEL</u>	<u>DESCRIPTION</u>	<u>LIST £</u>	
060725	VA-3-346 (A31720)	3/16", 1/4", 3/8" solder 3 size valve	1.18	
060726	VA-39 (A31729)	3/16", 1/4", 5/16", 3/8", 1/2" solder 9 size valve	1.67	
060727	VA-34 (A31723)	3/16" ID, 1/4" OD solder 2 size valve	1.18	060725 060726 060727
060728	VA-46 (A31724)	1/4" ID, 3/8" OD solder 2 size valve	1.18	
060729	VAU-24 (A31482)	1/8" MPT half union	1.55	060729
060730	VAU-45 (A31484)	1/4" MPT half union	1.60	
060731	VAX-2 (A31002)	1/8" OD extended copper tube valve	2.04	060733
060732	VAX-3 (A31003)	3/16" OD extended copper tube valve	2.22	
060733	VAX-4 (A31004)	1/4" OD extended copper tube valve	2.22	
060734	VAX-5 (A31005)	5/16" OD extended copper tube valve	2.42	
060735	VAX-6 (A31006)	3/8" OD extended copper tube valve	2.82	
060736	VE-2 (A31492)	1/8" MPT threaded elbow	3.12	
060737	VS-4 (A31734)	1/4" female flare swivel nut	3.76	060737
060750	VT-4 (A31444)	1/4" male flare equal tee with 2 flare nuts	2.96	060750
060738	VST-4 (A31852)	1/4" male fl x 1/4" male fl x 1/4" female fl swivel nut complete with depressor swivel tee - access on run	5.19	
060739	VST-44 (A31851)	1/4" male fl x 1/4" female fl swivel nut complete with depressor x 1/4" male fl swivel tee - access on branch	5.19	060738
060740	VT-24 (A31452)	1/4" male fl x 1/4" male fl x 1/8" MPT tee - access on run	2.62	060742
060741	VTR-24 (A31512)	1/8" MPT x 1/4" male fl x 1/4" male fl tee - access on branch	2.96	
060742	VT-44 (A31864)	1/4" male fl x 1/4" female fl swivel nut x 1/4" male fl tee - access on branch	2.96	060742
060743	VT-64 (A31854)	1/4" male fl x 1/4" male fl x 1/4" female fl swivel nut tee - access on run	2.96	
060744	VTS-46 (A31134)	1/4" ID, 5/16" OD solder tee	2.42	060744
060745	VTS-56 (A31135)	5/16" ID, 3/8" OD solder tee	2.42	
060746	VTS-68 (A31136)	3/8" ID solder tee	2.62	060747
060755	VTS-810 (A31138)	1/2" ID solder tee	2.96	
060747	VU-4 (A31614)	1/4" female flare union	2.42	060747
060748	VUR-4 (A31424)	1/4" flare union with flare nuts	2.06	060748
060749	VVC-1 (A31999)	Pack of 5 spare valve cores	1.59	060749
060425	QC-4 (NFT5-4)	1/4" flare Quick Cap sealing brass cap	0.59	060425
060724	QC-6 (NFT5-6)	3/8" flare Quick Cap sealing brass cap	1.43	
<u>VALVE CORE REMOVAL TOOLS</u>				
060764	VCR-1	Core remover and storage with 4 cores	6.20	060764 060765
060765	A32004	Core remover and threading tool with 6 cores	8.17	
060333	18975	Ball valve 4 in 1 vacuum/charge valve and core tool with 1/4" flare side port	39.05	060333

VACUUM GAUGES

SUPCO



The **VG60** electronic vacuum gauge is a durable self-contained battery powered vacuum gauge which displays the level of vacuum on an LED colour coded read-out. Allows for reading in 10 segments from atmosphere to 50 microns. The unique design of the VG60 allows for inline connection through the system or directly at the vacuum pump.



The **VG64** electronic vacuum gauge is a versatile high precision battery operated digital vacuum gauge offering the user 7 different measurement scales. Has ultra fine resolution (1 micron when vacuum <200 microns). Displays update each 1/2 second, has a convenient built-in hanger and its cleaning port provides quick cleaning and drying of sensor.

CODE	MODEL	LIST £	CODE	MODEL	LIST £
060653	VG60 electronic vacuum gauge	170.58	060658	VG64 electronic vacuum gauge	177.97

The **VG62** analogue vacuum gauge features a large 5" analogue meter, a range of 5000 to 10 microns and a vacuum sensor compatible with oils, refrigerants or cleaning solutions. The vacuum sensor never has to be replaced, simply cleaned, and can endure pressures up to 500PSI. The VG62 uses a thermistor type sensor and has a low battery/power on indicator LED.

060656	VG62 analogue vacuum gauge	243.78
--------	----------------------------	--------

YELLOW JACKET®

Yellow Jacket LCD vacuum gauges combine thermocouple sensor technology with advanced IC electronics for precise readings and repeatability not found with thermistor sensors or analogue meters. The result - accurate readings from 1999 to 1 micron without calibration on job after job.

The 69075 increases range to sense from atmospheric pressure down to 1 micron. It has also new electronics and a coiled cord. Thermocouple technology has long been proven in laboratory and precision industrial instrumentation for sensing the deep vacuum range. Thermocouple sensors are factory calibrated and exhibit few of the electronic variances of thermistor sensors found in many other electronic gauges.

060650	69075 SuperEvac™ LCD vacuum gauge	269.44
060651	69080 Digital LCD vacuum gauge with battery, hook and case	143.81



Connect this easy to read bar graph gauge directly to the system, pump, or in line, and know where you are in the evacuation process. Track down 14 increments from atmosphere to 25 microns to know that the system is clean and your vacuum pump is performing properly.

- Unique thermal conductivity sensor automatically compensates for temperature with no calibration
- Automatic battery saver shuts gauge off after 20 minutes of no reading changes (current vacuum displayed when turned back on)
- Low battery indicator

TIF

The **TIF9450D Digital Micron Gauge** is based on patented, non-thermistor technology which doesn't require you to calibrate for fluctuating room and/or sensing housing temperatures. The TIF9450D registers vacuum readings from a few microns up to 760,000 microns (1 atmosphere, 760mmHG or 0psig).

060652	TIF9450D Digital micron gauge	281.00
--------	-------------------------------	--------



VACUUM PUMPS & OIL

YELLOW JACKET® 2-STAGE VACUUM PUMPS



93357

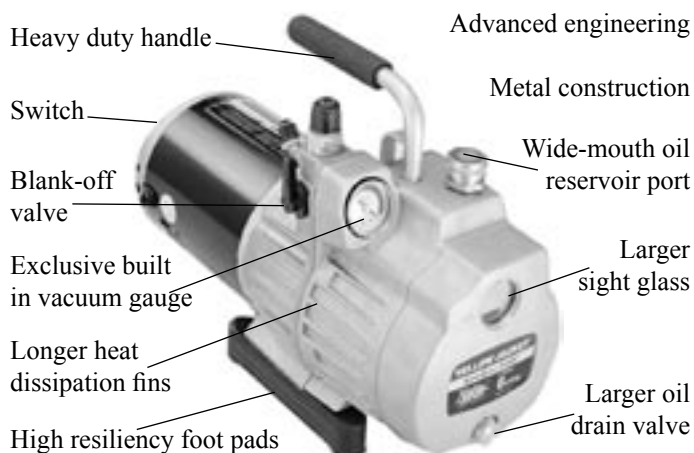

- High efficiency. CFM rated as 'free air displacement'. 15 micron field rating. The lower the micron number - the better the pump.
- Vacuum indicator gauge at the pump intake fitting shows evacuation progress down to the green 29" to 30" range, so you'll know when to turn on electronic gauge for more precise readings.
- Heavy duty torque motor assures cold weather starting.
- Gas ballast speeds evacuation and keeps oil cleaner.
- Low operating temperature to improve efficiency and vacuum.
- Large oil reservoir to help reduce operating temperature and better dilute corrosive contaminants.

<u>CODE</u>	<u>MODEL</u>	<u>CAPACITY</u> <u>LTR/CFM</u>	<u>VACUUM</u> <u>MICRONS</u>	<u>INTAKE</u>	<u>MOTOR</u> <u>HP-KW</u>	<u>VOLTAGE</u>	<u>WEIGHT</u> <u>KG</u>	<u>LIST £</u>
060649	93357 *	35/1.25	15	1/4" x 3/8" male fl	1/6-0.12	230V 50/60Hz	9.1	376.25
060659	93527	48/1.7	15	1/4" x 1/2" male fl	1/2-0.37	115/230V 50/60Hz	12.9	443.08
060661	93547	95/3.3	15	1/4" x 1/2" male fl	1/2-0.37	115/230V 50/60Hz	13.4	474.40
060663	93567	142/5.0	15	1/4" x 1/2" male fl	1/2-0.37	115/230V 50/60Hz	14.3	510.46
060665	93587	190/6.7	15	1/4" x 1/2" male fl	1/2-0.37	115/230V 50/60Hz	15.4	731.16

* Model 93357 - blank off valve not fitted

Full range of spares available

ITE 2-STAGE VACUUM PUMPS



- Equipped with gas ballast valve.
- Very low ultimate vacuum depth for maximum dehydration.
- Exhaust filter on oil inlet.
- Oil non-return trap.
- Thermal overload protection.
- Cold start (pneurop = +12°C): +4°C.
- Operating temperature of +65°C.
- Low noise level.

<u>CODE</u>	<u>MODEL</u>	<u>CAPACITY</u> <u>LTR/CFM</u>	<u>VACUUM</u> <u>MICRONS</u>	<u>INTAKE</u>	<u>MOTOR</u> <u>HP-KW</u>	<u>VOLTAGE</u>	<u>WEIGHT</u> <u>KG</u>	<u>LIST £</u>
060643	MK35-DS	35/1.25	30	1/4" male fl	1/4-0.18	230V 50/60Hz	6	348.46
060645	MK115DS/DV	115/4.1	25	3/8" male fl	1/2-0.37	110/230V 50/60Hz	15	424.70
060647	MK162DS/DV	162/5.78	20	1/2" male fl	1/2-0.37	110/230V 50/60Hz	15.5	470.42

VACUUM PUMP OIL

<u>CODE</u>	<u>DESCRIPTION</u>	<u>LIST £</u>
060668	93092 Yellow Jacket vacuum pump oil - quart	6.50
060625	Virginia vacuum pump oil - 3.78 litres	17.43
060626	Virginia vacuum pump oil - 0.9 litre	5.54
060627	Eurovac vacuum pump oil - 1 litre	12.66

RECOVERY EQUIPMENT

YELLOW JACKET®

- Recover most CFC, HCFC and HFC refrigerants including R410A (R63a & R73a).
- Fast recovery with pumping straight liquid refrigerant at up to 8 lbs/min and vapour at 2 lbs/min.
- Durability with proven 1/2 HP oil-less direct drive compressor on R63a & R73a. Twin cylinder 1 HP oil-less compressor for R100.
- Built-in 200 mesh particulate filter to protect from dirty systems.
- 'On-the-fly' purge with simple turn of a knob to remove residual refrigerant and help prevent cross contamination.
- Quiet running with components nested to reduce vibration and noise. Oil-less compressor is inherently quiet. R63a and R73a are housed in a tough polypropylene case for lightweight but rugged use.



R100



R63a



R73a

Start with the features of the R63a and add fully automatic operation. The new **R73a Universal Refrigerant Recovery System** is the first truly automatic recovery system for most refrigerants. There's not even a switch to touch for R410A. And you can run at record speed with totally automatic changeover from liquid to vapour.

<u>CODE</u>	<u>MODEL</u>	<u>CAPACITYKG/HR (MAX)</u>		<u>VOLTAGE</u>	<u>WEIGHT</u>	<u>LIST £</u>
		<u>VAPOUR</u>	<u>LIQUID</u>			
062115	94967 - R63a	15	98	230V 50Hz	13.5kg	916.16
062116	94965 - R65a	15	98	110V 50Hz	13.5kg	916.16
062118	94977 - R73a	28	72	230V 50Hz	13.5kg	1099.07
062119	95101 - R100	16	140	230V 50Hz	21.8kg	1466.49

ITE

MINI-R



MINI-R/2 A lightweight, portable unit suitable for use with CFC, HCFC and HFC refrigerants. Supplied with heavy duty hoses fitted with ball valves and pulse-free 80mm diameter gauges. Also equipped with quick connectors for easy hook up to the optional CM1 cleaning device.

CM1 OPTIONAL CLEANING MODULE - oil separator and heat exchanger, micronic filter drier, acid removal, and moisture indicator. Easy hookup to MINI-R/2.

MAXI-R Fitted with an oil-less compressor, this unit automatically recovers liquid and/or vapour. Suitable for all CFC, HCFC and HFC refrigerants. Equipped with a self discharging mode allowing to switch from one refrigerant to another without cross contamination.

MAXI-R



CM1



<u>CODE</u>	<u>MODEL</u>	<u>CAPACITYKG/HR (MAX)</u>		<u>VOLTAGE</u>	<u>WEIGHT</u>	<u>LIST £</u>
		<u>VAPOUR</u>	<u>LIQUID</u>			
062110	MINI-R/2	7	7	220/240V 50Hz	10.8kg	890.36
062112	MAXI-R	35	82	220/240V 50Hz	17kg	1115.78
062113	CM1	Cleaning module				271.94

RECOVERY EQUIPMENT

JAVAC

- New oil-less compressor, liquid tolerant, high recovery rates
- Automatic liquid/vapour regulator
- R410a compatible plus all common refrigerants
- Light weight 12Kg
- Tough construction

Vacuum 900mBar, 28" Hg. Built-in high pressure cut-off 32Bar.



REFRIGERANT

RECOVERY KG/HR

LIQUID

VAPOUR

R22	69	13
R410a	50	12
R134a	60	11

CODE MODEL

LIST £

062125 XTR refrigerant recovery machine 230V 50Hz 1043.28

ECO BUDDY

The lightweight EcoBuddy offers a highly efficient and easy to use solution for reclaiming refrigerant gases, which has not only become an environmental necessity, but a legal requirement.

- Liquid recovery rate up to 80kg/hr
- Vapour recovery rate up to 30kg/hr
- Large condenser and high air flow
- 500W oil-less compressor
- Suitable for most types of refrigerant, both liquid and vapour
- Shoulder straps (easy carry)
- Auxillary socket
- Includes light and tool drawer
- Rugged moulded case



CODE MODEL

LIST £

062130	EcoBuddy 230V	895.52
062131	EcoBuddy 110V	895.52
062132	EcoBuddy with purge facility 230V	938.17
062133	EcoBuddy with purge facility 110V	938.17

CAREMASTER

- Liquid and vapour recovery with automatic changeover
- Self discharging and Hot Gas/Cool Gas discharge switch
- Suitable for all CFC, HCFC, HFC, and HC refrigerants used on domestic, commercial and automotive refrigeration and air conditioning equipment
- Onboard refrigerant storage capability
- High efficiency heat exchanger and inlet oil separator with drain facility and integral mesh strainer
- Automatic high and low pressure safety switches with illuminated indicators and manual low pressure override switch
- Compressor fan cooling and compact air cooled condenser
- High electrical specification with encapsulated components
- Supplied with ball valve hoses



CODE MODEL

LIST £

Refrigerants: R12; R22; R134A; R404A; R407C; R410A; R413A; R417A; R502; R600A; R290.

062140 Caremaster Universal 230V 962.69

Recovery capacity to 18 kg/hr.

Onboard storage capacity: 250g.

Ambient temperature rating: 50°C



Surbiton: 020 8399 7151 Edinburgh: 0131 659 5333

RECOVERY EQUIPMENT

REFRIGERANT SERVICE CYLINDERS

12KG Refrigerant Service Cylinders available with single and dual port valves.

<u>CODE</u>	<u>MODEL</u>	<u>LIST £</u>
060415	HMC-3 Service Cylinder with F111 single port valve	63.64
060417	HMC-3 Service Cylinder with F230 dual port valve	69.28

